

Asa's View

Preliminary Technical Information Report: Drainage Design

Prepared for:

Troy Johns
1004 W. 13th Street, Suite 220
Vancouver, WA 98660

Prepared by:



NW Consilio LLC
2410 NE 22nd Avenue
Portland, OR 97212

May 2022

CERTIFICATION

Asa's View

Preliminary Technical Information Report: Drainage Design

The technical material and data contained in this report was prepared under the direction and supervision of the undersigned, who seal, as a professional engineer licensed to practice as such, is affixed.



Prepared by Shawn Ellis, PE

TABLE OF CONTENTS

A.	Project Overview.....	1
B.	Approvals Conditions Summary.....	2
C.	Downstream Analysis.....	2
D.	Quantity Control Analysis and Design.....	2
D.1	Site Hydrology.....	2
D.2	Drainage Basins.....	2
D.2.1	Existing Site Drainage.....	2
D.1.2	Developed Site Drainage.....	4
D.3	Detention Storage.....	4
E.	Conveyance Systems Analysis and Design.....	5
F.	Water Quality Design.....	6
G.	Soils Evaluation.....	6
H.	Special Reports and Studies.....	6
I.	Other Permits.....	7
J.	Ground Water Monitoring Program.....	7
K.	Maintenance and Operations Manual.....	7
L.	References.....	7

LIST OF TABLES

Table 1.	24-Hour Design Storms
Table 2.	Existing Site Drainage Land Cover Conditions
Table 3.	Existing Site Peak Discharges
Table 4.	Developed Site Drainage Land Cover Conditions
Table 5.	Detention Storage Facility – Design and Adjusted Volumes
Table 6.	Flow Control Features
Table 7.	Proposed Site Discharges
Table 8.	Water Quality Storage Volume

LIST OF FIGURES

Figure 1.	Project Site Location
Figure 2.	Existing Site Drainage Area

LIST OF APPENDICES

Appendix A	Supporting Information
Appendix B	Model Output and Calculations
Appendix C	Preliminary Plans
Appendix D	Geotechnical Report

A. PROJECT OVERVIEW

The Project is located within the City of La Center, Washington (City) south of NE Lockwood Creek Road and just west of NE 24th Avenue. The site includes tax lots 209064-000 and 20121-000. Tax lot 209121-000 has an assigned address of 2313 NE Lockwood Creek Road, La Center, Washington 98629. The tax lots total about 16.47 acres based the current project site survey. The site location is shown on Figure 1. Preliminary plans for the project are included in Appendix C.

The site is located within the City's LDR-7.5 zone and the proposed development will include 68 residential lots ranging in size from 7,500 square feet (sf) to 10,201 sf (the largest lot). The 68 residential lots will total 524,594 sf (12.04 acres).

The development will include 10,900 sf of public park space in Tract B, in accordance with LCMC 18.147. The required park space is based on 0.25 acres of park space per 40 dwelling units for the number of lots exceeding the first 40 units. Stormwater facilities for management of water quality treatment and detention will be located on Tract A covering 39,411 sf (0.91 acres). Right-of-way dedication with the site will total 142,482 sf (3.27 acres).

A small (0.18 acre) Category 3 non-jurisdictional wetland has been identified in the center of the site along a ditch running north to south along a gravel road. An Oregon White Oak tree is located in the southeast portion of the development in Tract B. The tree will be retained as protected as part of park improvements.

This Technical Information Report (TIR) is provided as part of preliminary design for the proposed project. An updated and final TIR will be provided as project design progresses.

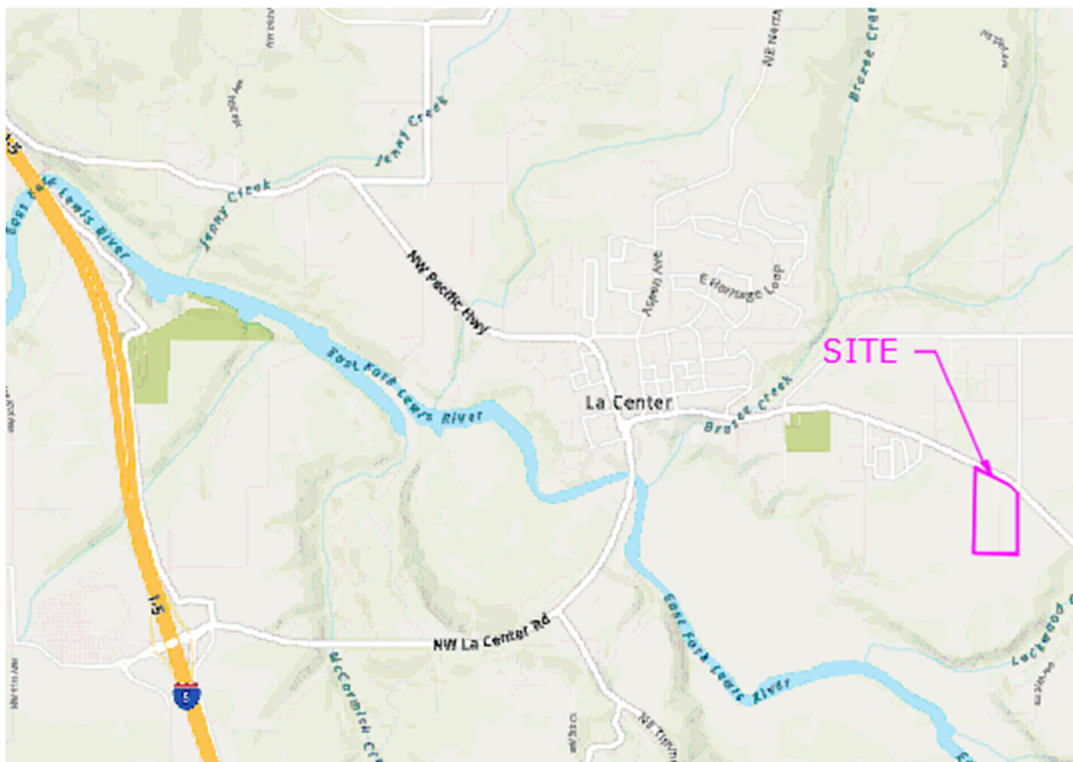

Figure 1. Project Site Location

B. APPROVALS CONDITIONS SUMMARY

Conditions of approval for the development will be provided after the Type III Land Use application has been processed, the City of La Center staff recommendations have been provided, and a public hearing has taken place.

C. DOWNSTREAM ANALYSIS

The project will provide on-site flow control in accordance with the City of La Center Municipal Code (LCMC) Section 18.320.220 (2)(b). The pre-development hydrologic analysis has assumed forested landcover conditions for the site, therefore an analysis of downstream conveyance capacity is not required.

D. QUANTITY CONTROL ANALYSIS AND DESIGN

An on-site detention pond is proposed in Tract A, located in the southwest corner of the site. The pond's detention volume will be above a permanent pool designated for water quality treatment (see Section F for the water quality design discussion).

D.1 Site Hydrology

Hydrologic calculations for the site have been completed using the HydroCAD[®] software model following the Santa Barbara Urban Hydrograph (SBUH) method for 24-hour rainfall depths distributed using the National Resources Conservation Service (NCRS) Type IA rainfall hyetograph. Design rainfall events for the project are listed in Table 1. Isopluvial maps of 24-hour rainfall events for Clark County are provided in Appendix A. Model output is included in Appendix B.

Table 1. 24-Hour Design Storms

Design Storm / Return Period	24-Hour Rainfall Depths (inches)
2-Year	2.4
10-Year	3.3
25-Year	3.8
100-Year	4.5

D.2 Drainage Basins

D.2.1 Existing Site Drainage

The existing project site (16.47 acres) and half of Lockwood Creek Road (0.52 acres) drains generally toward the southwest corner of the project area where it is conveyed off-site along an open drainage channel that runs southwesterly for discharge into Lockwood Creek which discharges into the Lewis River. A drainage channel near the center of the site is located along the east site of a road the runs through the site from the north to south. The road is located within a 60-foot Private Road and Utility Easement. The constructed ditch covering 0.18 acres has been identified as containing a non-jurisdictional Category 3 wetland. Figure 2 shows the existing site and basin outline.



Figure 2. Existing Site Drainage Area

Pre-development drainage conditions assume undisturbed forested land except for the 0.27 acres of pavement on Lockwood Creek Road that contributes to on-site drainage. The land cover areas and runoff Curve Numbers are summarized in Table 2 for existing drainage conditions analysis. The resultant peak flows for the existing conditions analysis summarized in Table 3.

Table 2. Existing Site Drainage Land Cover Conditions

Land Cover	Area (acres)	Curve Number
Lockwood Creek Road	0.27	98
Undisturbed Forest	16.73	76
Total Area	17.0	

Table 3. Existing Site Peak Discharges

Design Storm / Return Period	Peak Discharge (cfs)
2-Year	1.13
10-Year	2.88
25-Year	4.03
100-Year	5.80

D.1.2 Developed Site Drainage

Proposed site drainage will maintain the general drainage pattern for the site with the exception that some runoff generated on the east border of the site that currently drains to an off-site drainage ditch will be retained on-site and collected as part of the developments stormwater manage system. The area generally falls within the 20-foot backyard setback, so will primarily remain pervious.

The developed site drainage will include impervious surface areas for road pavement within the project area (3.27 acres), Lockwood Creek Road pavement (0.47 acres), maximum lot impervious surface equal to 50 percent of the total lot coverage (6.02 acres), and the water surface of the stormwater management pond (0.56 acres). The balance of the site and right-of-way will be landscaped yards and the park in Tract B (6.68 acres). The areas and landcover conditions are summarized in Table 4. The drainage layout is shown on the preliminary drainage plans provided in Appendix C.

Table 4. Developed Site Drainage Land Cover Conditions

Land Cover	Area (acres)	Curve Number
Road Pavement	3.74	98
Lot Maximum Impervious Area	6.02	98
Pond Surface Area	0.56	98
Landscape / Park Area	6.68	74
Total Area	17.0	

D.3 Detention Storage

In accordance with LCMC Section 18.320.220, post-development discharges from the site must be less than or equal to the pre-project discharges for the 2-year, 10-year, 25-year, and 100-year design storms. The volume of water required to meet the design criteria must subsequently be adjusted (increased) to mitigate for runoff volumes that are underpredicted by 24-hour storm events. The correction factor recommended in the Puget Sound Manual (Section III-1.2) indicates correction factors of “20 percent and 50 percent apply to residential sites and commercial sites, respectively.” The 20 percent correction for this project has been applied to the design volume, resulting in a larger pond surface area (footprint). The design control features (orifice openings and overflow weir) remain unchanged from the initial design process.

HydroCAD output for the detention pond design is contain in Appendix B. The modeled stage-storage data for design of flow control is listed in Table 5. The adjusted values used for actual pond sizing is also listed. The constructed facility will be sized with the adjusted values. Flow control features for the facility are listed in Table 6. Storage for detention occurs above elevation 131 feet in the ponds. The volume below elevation 131 feet is the permanent pool for water quality treatment (see Section F). Site discharges for the design storms are summarized in Table 7, which also lists the target discharge rates based on pre-development analysis.

Table 5. Detention Storage Facility – Design and Adjusted Volumes

Stage (feet)	Pond Design Per SBUH		Pond Size Per Applied Correction Factor	
	Area (sf)	Volume (cf)	Area (sf)	Volume (cf)
131	15,853	0	19,587	0
132	17,369	16,611	21,239	20,413
133	18,942	18,156	22,948	22,094
134	20,572	19,757	24,713	23,831

Table 6. Flow Control Features

Flow Control Element	Elevation (feet)	Diameter (inches)
Detention Storage Bottom Elevation	131.00	-
Flow Control Outlet Pipe Invert	131.00	-
Low Flow Orifice	131.00	5.7
Second Orifice	132.75	9.6
Overflow	133.46	12

Table 7. Proposed Site Discharges

Design Storm / Return Period	Peak Discharge (cfs)	Water Surface at Peak Flow	Target Discharge (cfs)
2-Year	1.13	132.75	1.13
10-Year	2.84	133.18	2.87
25-Year	3.52	133.50	4.04
100-Year	5.79	133.78	5.92

E. CONVEYANCE SYSTEMS ANALYSIS AND DESIGN

Design of the collection and conveyance system has been completed following the Rational Method and rainfall intensities based on the design storm with a 100-year recurrence interval. The intensity is determined in accordance with the Washington State Department of Transportation Hydraulics Manual based on time of concentration (TOC) and rainfall coefficients as follows:

$$I = m \sqrt[n]{(TOC^n)}$$

The values for the coefficients ($m = 8.75$ and $n = 0.527$) are averaged between the values provided for the City of Vancouver and the Kelso/Longview area. The reference data is provided in Appendix X.

A spreadsheet summarizing design of the stormwater conveyance system is provided in Appendix X. Inlets have been spaced to capture no more than 7,000 square feet of impervious surface are in

accordance City criteria. Combination curb inlets will be provided on longitudinal road slopes exceeding 2 percent. Standard curb inlets will be provided elsewhere within the developed site. On Lockwood Creek Road, catch basin inlets will be provided to allow for pipe connections between the structures within the street area (not under the sidewalk).

F. WATER QUALITY DESIGN

Water quality treatment for the Project will be provided in a three-celled wet pond facility. Treatment is designed based on the volume of runoff generated by 24-hour design event with a 6-month return period. This storm is the water quality design storm and is assumed to be 64 percent of the 2-year, 24-hour design storm, or 1.54 inches. The water quality volume was calculated using the SBUH design methods and land use assumptions described in Section D.

The water quality volume for the site totals 52,751 cf (1.211 acre-feet). Hydrocad® model output is contained in Appendix B. The water quality volume will be located between elevations 127 feet and 131 feet in the treatment cells beneath the detention storage portion of the detention pond. The volume in the first cell below elevation 128 feet is not included as part of the water quality volume. The treatment cells will be separated with earthen berms with overflows at elevation 128 between Cell 1 and Cell 2 and at elevation 130 between Cell 2 and Cell 3. The calculated water quality stage storage and resultant volume is summarized in Table 8. The pond has a water quality storage volume of 56,780 cf.

Table 8. Water Quality Storage Volume

Elevation (feet)	Cell #2 Area (sf)	Cell #3 Area (sf)	Combined Areas (sf)	Pond Volume (cf)
127	4,036	5,010	9,046	-
128	4,906	6,086	10,992	10,019
129	7,242	7,218	14,460	22,745
130	-	-	17,011	38,481
131	-	-	19,587	56,780

G. SOILS EVALUATION

A geotechnical investigation for the site was completed on March 25th and April 4th, 2022 by Soil and Water Technologies, Inc. (SWT). A report summarizing their findings is included in Appendix D. Based on the results of the investigation, infiltration of stormwater runoff is not recommended.

Groundwater elevations are reported to vary seasonally for the site and surrounding area. Seepage was encountered at depths ranging from 2 feet to 5 feet below ground surface at three of four test pits completed at the site. Static groundwater elevations reportedly exceed 30 feet in depth, and observed seepage is likely due to recent rainfall events.

Infiltration testing was completed for the location of the proposed stormwater management facility, in the southwest corner of the site. Groundwater was not observed during the test excavation activities, however test results indicated infiltration rates of 0.08 and 0.05 inches per hour for two tests completed.

H. SPECIAL REPORTS AND STUDIES

A wetland delineation for the site was completed by Environmental Technology Consultants. The work and results are documented in a report dated February 25, 2022. The report, which is submitted under separate cover, identified the presence of a 0.18-acre non-jurisdictional wetland rated as Category 3.

I. OTHER PERMITS

Permits for the proposed development will include a Grading Permit, Building Permit, and a Construction Permit (NPDES). The project requires review in accordance with the State Environmental Policy Act (SEPA). SEPA documents have been submitted separately from this TIR.

J. GROUND WATER MONITORING PROGRAM

No groundwater monitoring program is proposed.

K. MAINTENANCE AND OPERATIONS MANUAL

Operation and maintenance of the stormwater treatment and detention pond and the flow control structure will be the responsibility of the development Homeowners Association. An Operation and Maintenance Manual for the facilities will be completed as part of the final design and will be included as part of the final TIR for stormwater management.

L. REFERENCES

City La Center, "La Center Municipal Code," Title 18 – Development Code. Updated February 9, 2022.

Washington State Department of Ecology – Water Quality Program. "Stormwater Management Manual for the Puget Sound Basin", Publication 91-75. Dated February 1999.

Washington State Department of Transportation. "Hydraulics Manual", Publication M23-03.07. Dated March 1, 2022.

Appendix A.

Supporting Data

Isopluvial Map for Clark County 2-Year, 24-Hour Design Storm

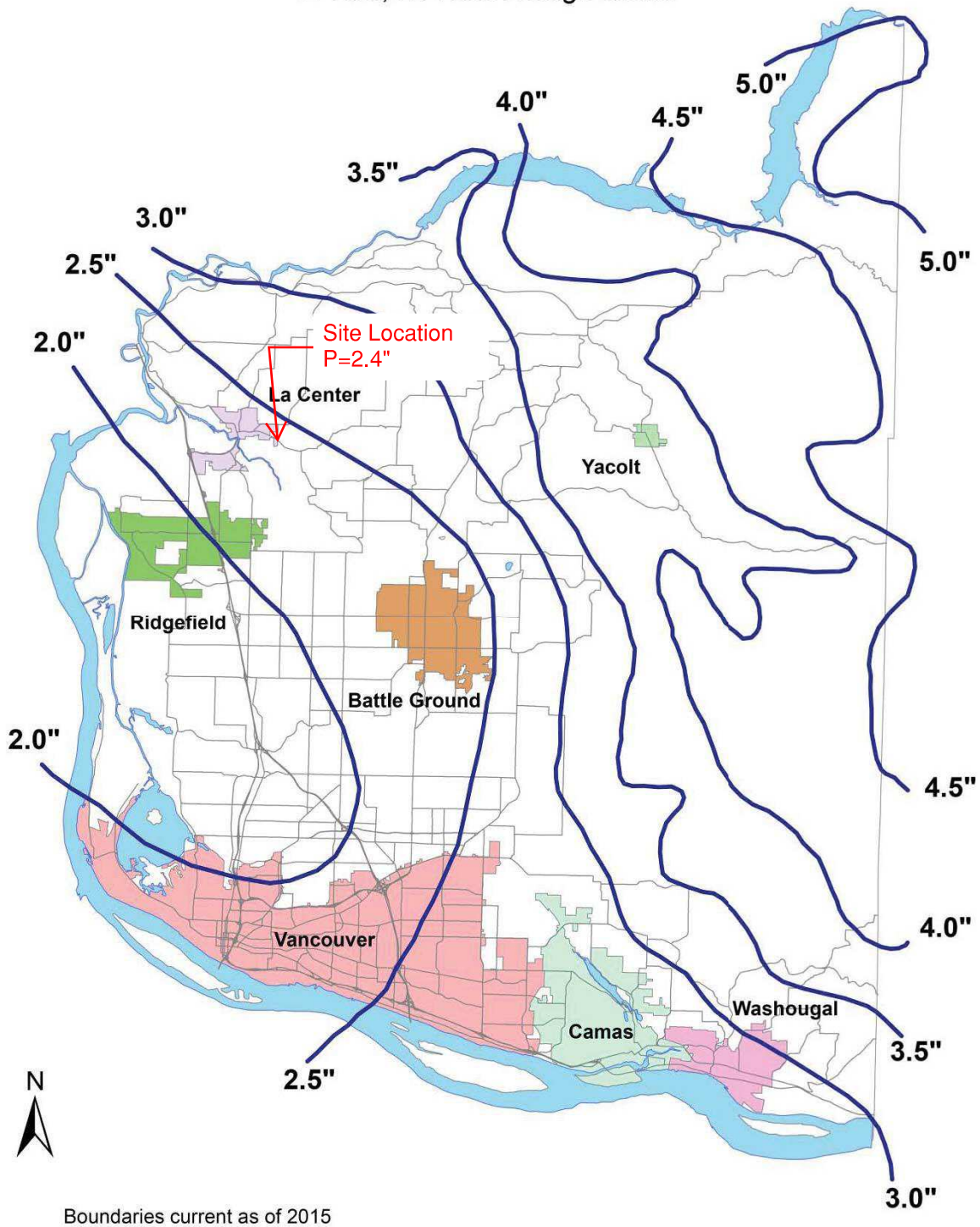

Isopluvial Map for Clark County

10-Year, 24-Hour Design Storm

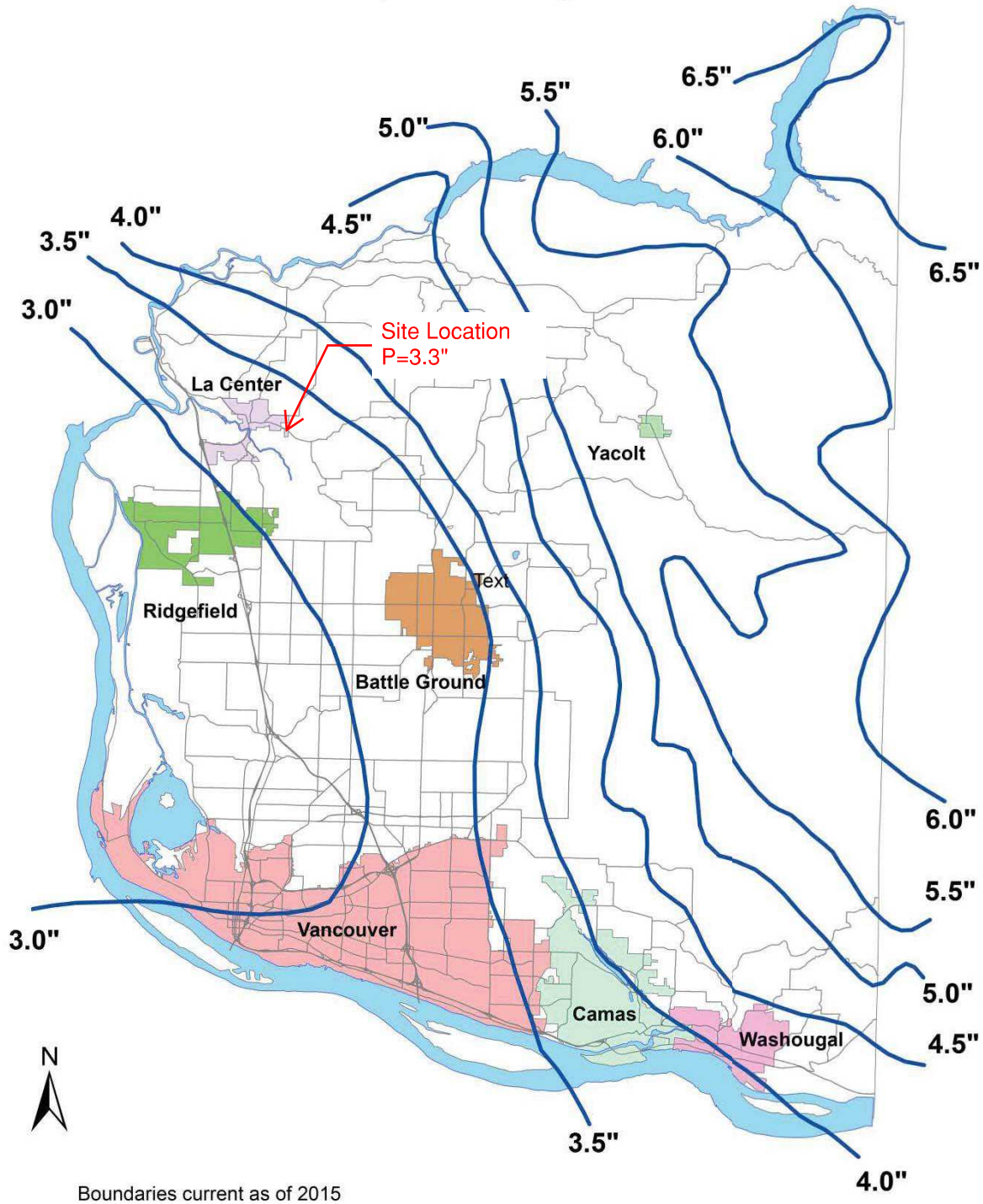

Isopluvial Map for Clark County 25-Year, 24-Hour Design Storm

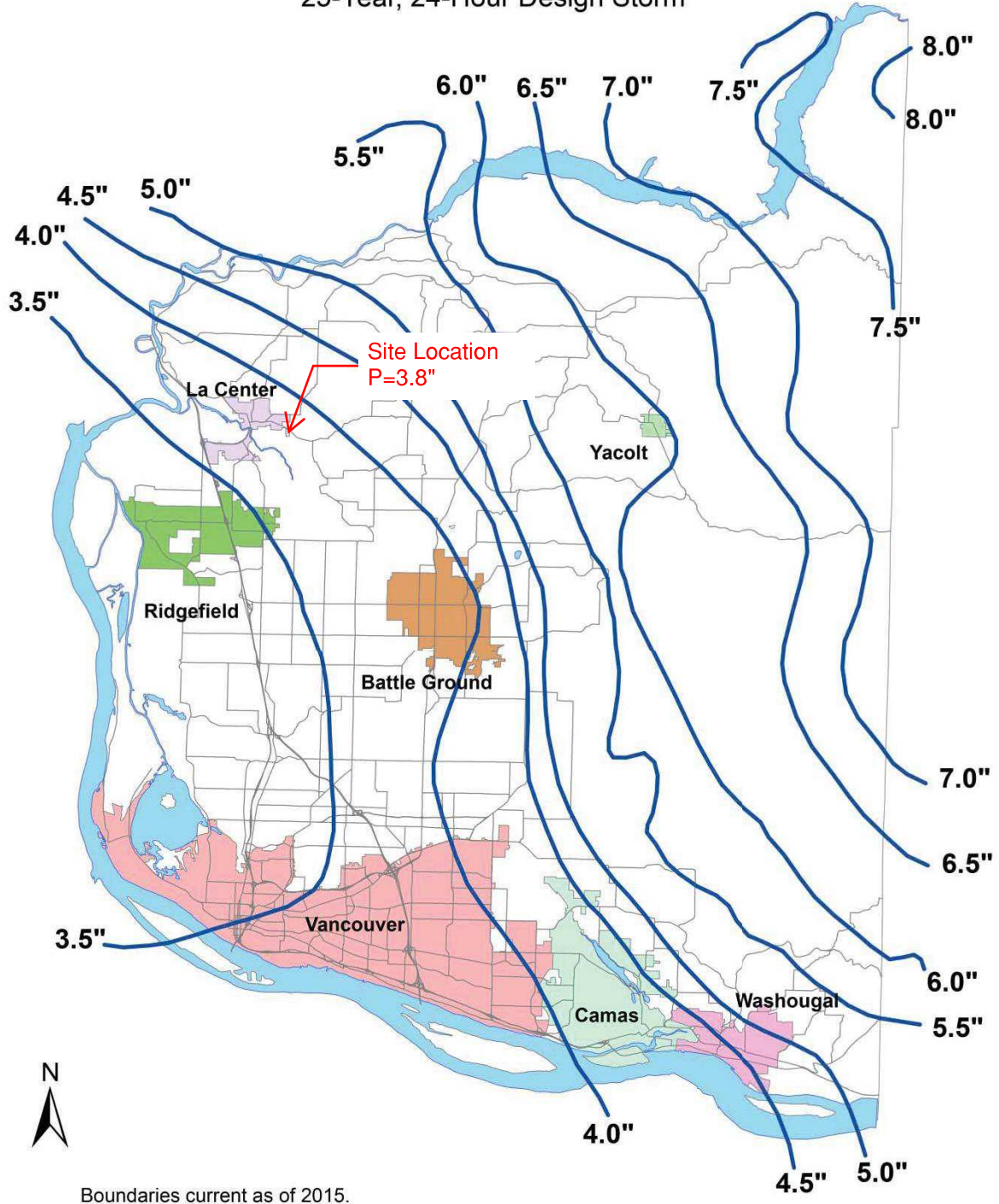

Isopluvial Map for Clark County

100-Year, 24-Hour Design Storm

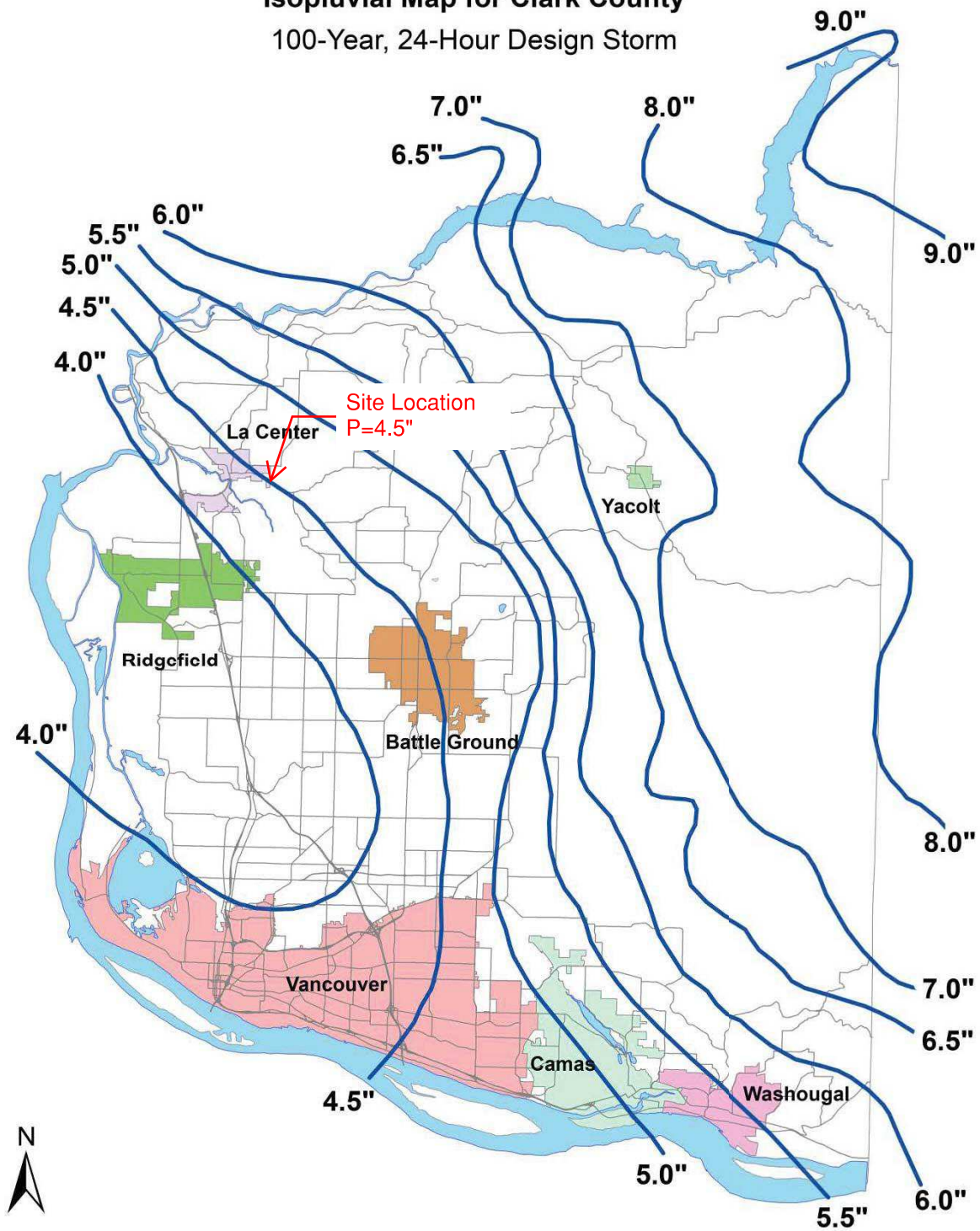

Boundaries current as of 2015.

Table 2-4 Inches to Rainfall Coefficients

Location	2-Year MRI		5-Year MRI		10-Year MRI		25-Year MRI		50-Year MRI		100-Year MRI	
	m	n	m	n	m	n	m	n	m	n	m	n
Aberdeen and Hoquiam	5.10	0.488	6.22	0.488	7.06	0.487	8.17	0.487	9.02	0.487	9.86	0.487
Bellingham	4.29	0.549	5.59	0.555	6.59	0.559	7.90	0.562	8.89	0.563	9.88	0.565
Bremerton	3.79	0.480	4.84	0.487	5.63	0.490	6.68	0.494	7.47	0.496	8.26	0.498
Centralia and Chehalis	3.63	0.506	4.85	0.518	5.76	0.524	7.00	0.530	7.92	0.533	8.86	0.537
Clarkston and Colfax	5.02	0.628	6.84	0.633	8.24	0.635	10.07	0.638	11.45	0.639	12.81	0.639
Colville	3.48	0.558	5.44	0.593	6.98	0.610	9.07	0.626	10.65	0.635	12.26	0.642
Elensburg	2.89	0.590	5.18	0.631	7.00	0.649	9.43	0.664	11.30	0.672	13.18	0.678
Everett	3.69	0.556	5.20	0.570	6.31	0.575	7.83	0.582	8.96	0.585	10.07	0.586
Forks	4.19	0.410	5.12	0.412	5.84	0.413	6.76	0.414	7.47	0.415	8.18	0.416
Hoffstadt Cr. (SR 504)	3.96	0.448	5.21	0.462	6.16	0.469	7.44	0.476	8.41	0.480	9.38	0.484
Hoodsport	4.47	0.428	5.44	0.428	6.17	0.427	7.15	0.428	7.88	0.428	8.62	0.428
Kelso and Longview	4.25	0.507	5.50	0.515	6.45	0.509	7.74	0.524	8.70	0.526	9.67	0.529
Leavenworth	3.04	0.530	4.12	0.542	5.62	0.575	7.94	0.594	9.75	0.606	11.08	0.611
Metaline Falls	3.36	0.527	4.90	0.553	6.09	0.566	7.45	0.570	9.29	0.592	10.45	0.591
Moses Lake	2.61	0.583	5.05	0.634	6.99	0.655	9.58	0.671	11.61	0.681	13.63	0.688
Mt. Vernon	3.92	0.542	5.25	0.552	6.26	0.557	7.59	0.561	8.60	0.564	9.63	0.567
Naselle	4.57	0.432	5.67	0.441	6.14	0.432	7.47	0.443	8.05	0.440	8.91	0.436
Olympia	3.82	0.466	4.86	0.472	5.62	0.474	6.63	0.477	7.40	0.478	8.17	0.480
Omak	3.04	0.583	5.06	0.618	6.63	0.633	8.74	0.647	10.35	0.654	11.97	0.660
Pasco and Kennewick	2.89	0.590	5.18	0.631	7.00	0.649	9.43	0.664	11.30	0.672	13.18	0.678
Port Angeles	4.31	0.530	5.42	0.531	6.25	0.531	7.37	0.532	8.19	0.532	9.03	0.532
Poulsbo	3.83	0.506	4.98	0.513	5.85	0.516	7.00	0.519	7.86	0.521	8.74	0.523
Queets	4.26	0.422	5.18	0.423	5.87	0.423	6.79	0.423	7.48	0.423	8.18	0.424
Seattle	3.56	0.515	4.83	0.531	5.62	0.530	6.89	0.539	7.88	0.545	8.75	0.5454
Sequim	3.50	0.551	5.01	0.569	6.16	0.577	7.69	0.585	8.88	0.590	10.04	0.593
Snogualmie Pass	3.61	0.417	4.81	0.435	6.56	0.459	7.72	0.459	8.78	0.461	10.21	0.476
Spokane	3.47	0.556	5.43	0.591	6.98	0.609	9.09	0.626	10.68	0.635	12.33	0.643
Stevens Pass	4.73	0.462	6.09	0.470	8.19	0.500	8.53	0.484	10.61	0.499	12.45	0.513
Tacoma	3.57	0.516	4.78	0.527	5.70	0.533	6.93	0.539	7.86	0.542	8.79	0.545
Vancouver	2.92	0.477	4.05	0.496	4.92	0.506	6.06	0.515	6.95	0.520	7.82	0.525
Walla Walla	3.33	0.569	5.54	0.609	7.30	0.627	9.67	0.645	11.45	0.653	13.28	0.660
Wenatchee	3.15	0.535	4.88	0.566	6.19	0.579	7.94	0.592	9.32	0.600	10.68	0.605
Yakima	3.86	0.608	5.86	0.633	7.37	0.644	9.40	0.654	10.93	0.659	12.47	0.663

City of La Center: m = 8.75
n = 0.527

Appendix B.
Calculations
Hydrocad Model Output

Pipe Flow Conveyance and Capacity

Project Name: Asa' View Subdivision
 Project Location: La Center, Wa

Design Storm Event: 100
 Min. Time of Concentration: 5
 Manual input:
 Calculated Data:

Impervious C = 0.90
 Intensity, m = 8.75
 Intensity, n = 0.527
 Intensity (in/hr) = m / (TOCⁿ)

Pipe Segment						Impervious Area						Pipe Design Calculations										
Upstream		Downstream		Length	Slope	(sf)				(ac)		TOC (min)	ΣTOC (min)	intensity (in/hr)	Q	Dia (in)	Area (sf)	Pipe n	Hyd Rad	Full Flow Velocity	Capacity (cfs)	Capacity > Flow?
Structure	Invert	Structure	Invert			Road	Lot	50% Lot	Total	Total	Σ Total											
Pipe Segment: Lockwood Creek through NE 23 Loop																						
CB-01	148.87	CB-02	148.36	231	0.22%	6,930	0	0	6,930	0.16	0.16	5.00	5.00	3.75	0.283	12	0.7870	0.013	0.25	2.13	1.68	Yes
CB-02	148.36	MH-01	148.00	164	0.22%	4,920	0	0	4,920	0.11	0.27	1.80	6.80	3.19	0.411	12	0.7870	0.013	0.25	2.13	1.68	Yes
MH-01	147.80	MH-02	147.56	111	0.22%	0	0	0	0	0.00	0.27	1.28	8.09	2.91	0.375	12	0.7870	0.013	0.25	2.13	1.68	Yes
MH-02	147.36	CB-03	147.24	53	0.22%	0	0	0	0	0.00	0.27	0.87	8.95	2.76	0.356	12	0.7870	0.013	0.25	2.13	1.68	Yes
CB-03	147.24	MH-03	147.14	45	0.22%	4,920	0	0	4,920	0.11	0.38	0.41	9.37	2.69	0.491	12	0.7870	0.013	0.25	2.13	1.68	Yes
MH-03	146.94	MH-04	146.71	104	0.22%	3,330	0	0	3,330	0.08	0.46	0.35	9.72	2.64	0.578	12	0.7870	0.013	0.25	2.13	1.68	Yes
MH-04	146.51	MH-05	146.41	46	0.22%	6,931	0	0	6,931	0.16	0.62	0.81	10.53	2.53	0.745	12	0.7870	0.013	0.25	2.13	1.68	Yes
MH-05	146.21	MH-06	145.87	68	0.50%	0	0	0	0	0.00	0.62	0.36	10.89	2.49	0.732	12	0.7870	0.013	0.25	3.22	2.53	Yes
MH-06	145.67	MH-07	136.49	187	4.91%	0	0	0	0	0.00	0.62	0.35	11.24	2.44	0.719	12	0.7870	0.013	0.25	10.08	7.93	Yes
MH-07	136.29	MH-08	136.18	53	0.20%	11,203	56,917	28,459	39,662	0.91	1.53	0.31	11.55	2.41	1.750	15	1.2297	0.013	0.31	2.36	2.90	Yes
MH-08	135.98	MH-09	135.38	302	0.20%	0	0	0	0	0.00	1.53	0.37	11.93	2.37	1.721	15	1.2297	0.013	0.31	2.36	2.90	Yes
MH-09	135.18	MH-10	134.66	261	0.20%	30,663	154,776	77,388	108,051	2.48	4.01	2.13	14.06	2.17	4.134	18	1.7708	0.013	0.38	2.67	4.72	Yes
MH-10	134.46	MH-11	133.92	270	0.20%	11,764	45,037	22,519	34,283	0.79	4.80	1.63	15.69	2.05	4.667	18	1.7708	0.013	0.38	2.67	4.72	Yes
MH-11	133.72	MH-17	133.58	47	0.30%	11,494	67,777	33,889	45,383	1.04	5.84	1.69	17.38	1.94	5.383	18	1.7708	0.013	0.38	3.26	5.78	Yes
Pipe Segment: NE 23rd Avenue																						
MH-12	136.12	MH-13	135.57	276	0.20%	9,405	31,216	15,608	25,013	0.57	0.57	5.00	5.00	3.75	1.020	12	0.7870	0.013	0.25	2.03	1.60	Yes
MH-13	135.37	MH-14	134.79	288	0.20%	11,049	52,549	26,275	37,324	0.86	1.43	2.26	7.26	3.08	2.089	15	1.2297	0.013	0.31	2.36	2.90	Yes
MH-14	134.59	MH-15	134.51	42	0.20%	12,062	52,527	26,264	38,326	0.88	2.31	2.03	9.30	2.70	2.962	18	1.7708	0.013	0.38	2.67	4.72	Yes
MH-15	134.31	MH-16	134.04	134	0.20%	0	0	0	0	0.00	2.31	0.26	9.56	2.66	2.919	18	1.7708	0.013	0.38	2.67	4.72	Yes
MH-16	133.84	MH-17	133.58	116	0.22%	22,247	63,795	31,898	62,270	1.43	3.74	0.84	10.40	2.55	4.520	18	1.7708	0.013	0.38	2.80	4.95	Yes
Pipe Segment: Outfall to Pond																						
MH-17	133.41	Pond	131.00	65	3.71%	146,918	524,594	262,297	417,341	9.58	9.58	1.69	1.69	6.64	30.172	24	3.1480	0.013	0.50	13.91	43.78	Yes

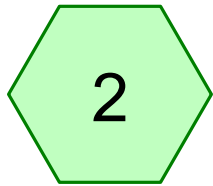

Developed Site

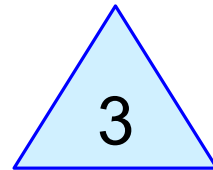

Pond

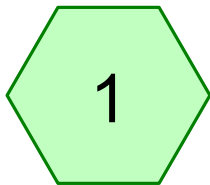

Undeveloped Site

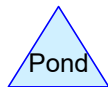
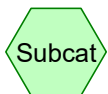

Rainfall Events Listing

Event#	Event Name	Storm Type	Curve	Mode	Duration (hours)	B/B	Depth (inches)	AMC
1	2-year	Type IA 24-hr		Default	24.00	1	2.40	2
2	10-year	Type IA 24-hr		Default	24.00	1	3.30	2
3	25-year	Type IA 24-hr		Default	24.00	1	3.80	2
4	100-year	Type IA 24-hr		Default	24.00	1	4.50	2
5	WQ	Type IA 24-hr		Default	24.00	1	1.54	2

AsaLockwood

Prepared by Microsoft

HydroCAD® 10.10-7a s/n 12389 © 2021 HydroCAD Software Solutions LLC

Type IA 24-hr 2-year Rainfall=2.40"

Printed 5/1/2022

Page 3

Time span=0.00-24.00 hrs, dt=0.05 hrs, 481 points
Runoff by SBUH method, Split Pervious/Imperv.
Reach routing by Stor-Ind+Trans method - Pond routing by Stor-Ind method

Subcatchment1: UndevelopedSite Runoff Area=17.000 ac 1.59% Impervious Runoff Depth>0.65"
Flow Length=900' Slope=0.0500 '/' Tc=29.1 min CN=76/98 Runoff=1.13 cfs 0.915 af

Subcatchment2: Developed Site Runoff Area=17.000 ac 60.71% Impervious Runoff Depth>1.52"
Flow Length=1,325' Tc=25.6 min CN=74/98 Runoff=4.65 cfs 2.152 af

Pond 3: Pond Peak Elev=132.75' Storage=30,139 cf Inflow=4.65 cfs 2.152 af
Outflow=1.13 cfs 1.628 af

Total Runoff Area = 34.000 ac Runoff Volume = 3.067 af Average Runoff Depth = 1.08"
68.85% Pervious = 23.410 ac 31.15% Impervious = 10.590 ac

Summary for Subcatchment 1: Undeveloped Site

Runoff = 1.13 cfs @ 8.25 hrs, Volume= 0.915 af, Depth> 0.65"

Runoff by SBUH method, Split Pervious/Imperv., Time Span= 0.00-24.00 hrs, dt= 0.05 hrs
Type IA 24-hr 2-year Rainfall=2.40"

Area (ac)	CN	Description
* 16.730	76	Woods, Good, HSG C
* 0.270	98	Existing Lockwood
17.000	76	Weighted Average
16.730	76	98.41% Pervious Area
0.270	98	1.59% Impervious Area

Tc (min)	Length (feet)	Slope (ft/ft)	Velocity (ft/sec)	Capacity (cfs)	Description
17.2	100	0.0500	0.10		Sheet Flow, sheet flow
					Woods: Light underbrush n= 0.400 P2= 2.40"
11.9	800	0.0500	1.12		Shallow Concentrated Flow, Concentrated Flow
					Woodland Kv= 5.0 fps
29.1	900	Total			

Subcatchment 1: Undeveloped Site

Hydrograph

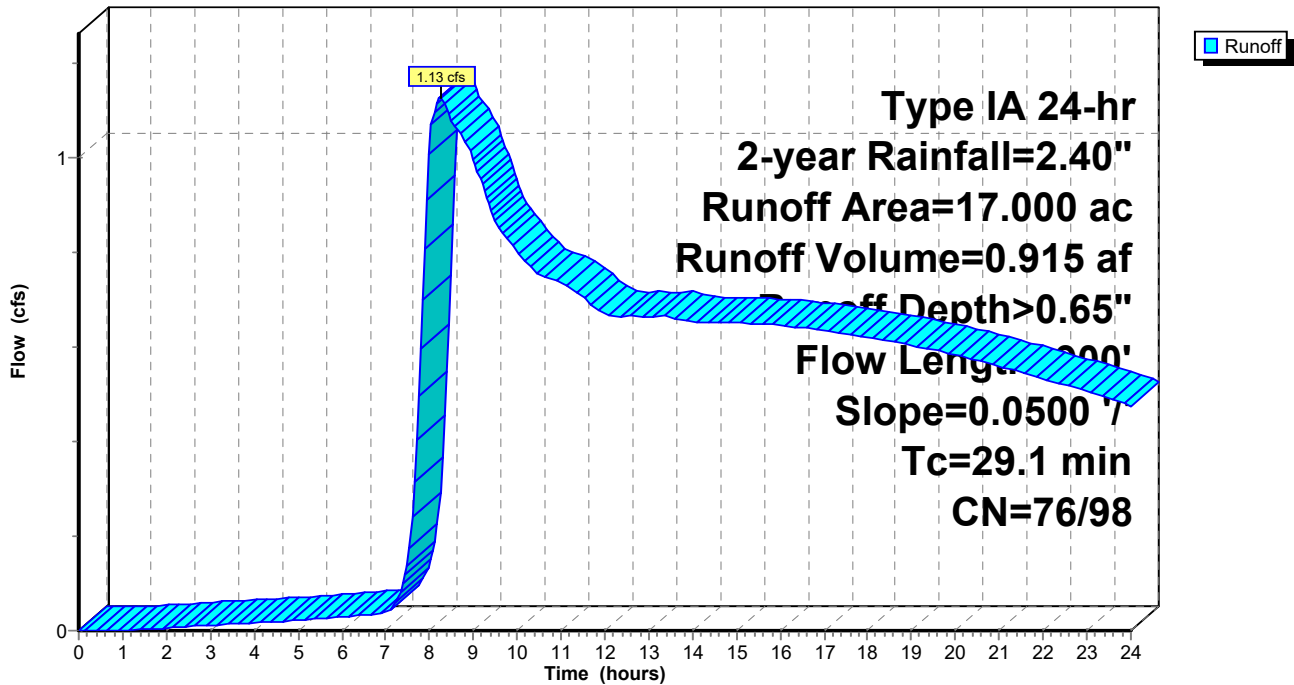

Summary for Subcatchment 2: Developed Site

[47] Hint: Peak is 17610% of capacity of segment #2

[47] Hint: Peak is 130% of capacity of segment #3

Runoff = 4.65 cfs @ 8.04 hrs, Volume= 2.152 af, Depth> 1.52"
 Routed to Pond 3 : Pond

Runoff by SBUH method, Split Pervious/Imperv., Time Span= 0.00-24.00 hrs, dt= 0.05 hrs
 Type IA 24-hr 2-year Rainfall=2.40"

Area (ac)	CN	Description
3.740	98	Paved roads w/curbs & sewers, HSG C
6.680	74	>75% Grass cover, Good, HSG C
* 6.020	98	Lot Impervious Area (maximum)
* 0.560	98	Detention Pond Surface Area
17.000	89	Weighted Average
6.680	74	39.29% Pervious Area
10.320	98	60.71% Impervious Area

Tc (min)	Length (feet)	Slope (ft/ft)	Velocity (ft/sec)	Capacity (cfs)	Description
13.5	125	0.0200	0.15		Sheet Flow, Lawn Sheet Flow Grass: Short n= 0.150 P2= 2.40"
8.4	200	0.0300	0.40	0.03	Parabolic Channel, Gutter W=0.50' D=0.20' Area=0.1 sf Perim=0.7' n= 0.140
3.7	1,000	0.0100	4.54	3.56	Pipe Channel, CMP_Round 12" 12.0" Round Area= 0.8 sf Perim= 3.1' r= 0.25' n= 0.013
25.6	1,325	Total			

Subcatchment 2: Developed Site

Hydrograph

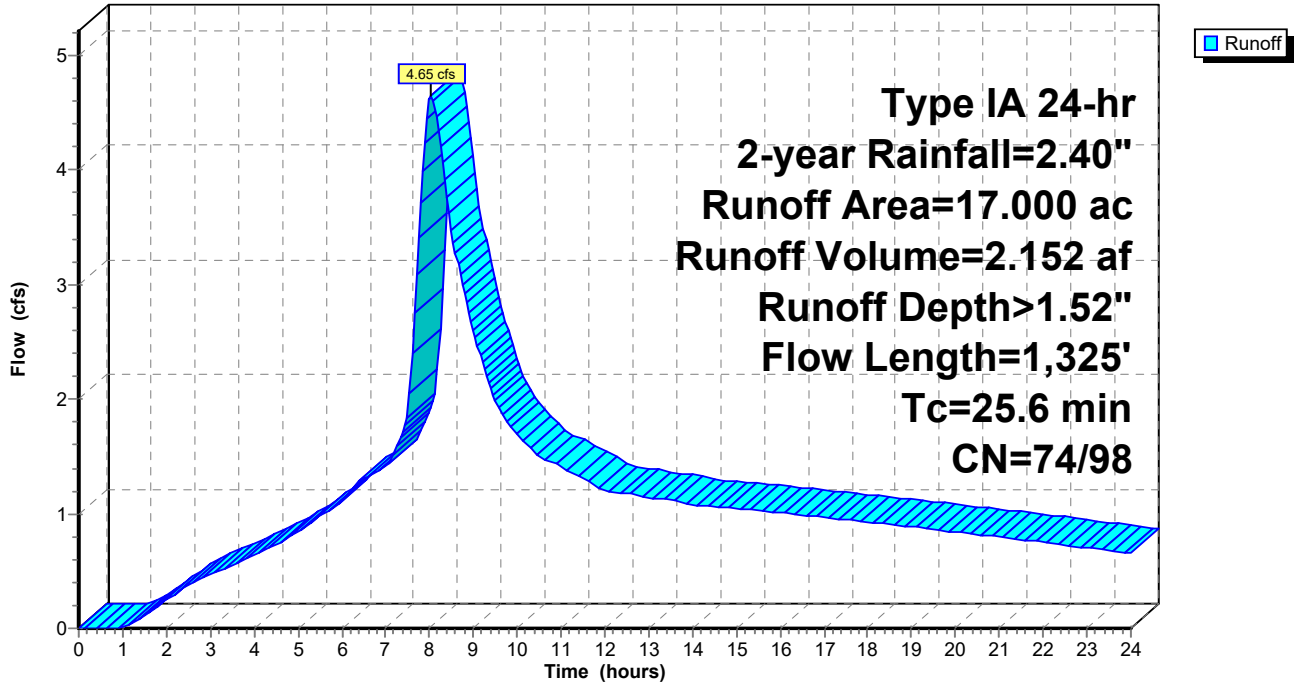

Summary for Pond 3: Pond

Inflow Area = 17.000 ac, 60.71% Impervious, Inflow Depth > 1.52" for 2-year event
 Inflow = 4.65 cfs @ 8.04 hrs, Volume= 2.152 af
 Outflow = 1.13 cfs @ 13.26 hrs, Volume= 1.628 af, Atten= 76%, Lag= 313.2 min
 Primary = 1.13 cfs @ 13.26 hrs, Volume= 1.628 af

Routing by Stor-Ind method, Time Span= 0.00-24.00 hrs, dt= 0.05 hrs
 Peak Elev= 132.75' @ 13.26 hrs Surf.Area= 18,554 sf Storage= 30,139 cf

Plug-Flow detention time= 316.7 min calculated for 1.624 af (75% of inflow)
 Center-of-Mass det. time= 164.0 min (885.1 - 721.1)

Volume	Invert	Avail.Storage	Storage Description
#1	131.00'	54,524 cf	Custom Stage Data (Prismatic) Listed below (Recalc)

Elevation (feet)	Surf.Area (sq-ft)	Inc.Store (cubic-feet)	Cum.Store (cubic-feet)
131.00	15,853	0	0
132.00	17,369	16,611	16,611
133.00	18,942	18,156	34,767
134.00	20,572	19,757	54,524

Device	Routing	Invert	Outlet Devices
#1	Primary	131.00'	5.7" Horiz. Orifice/Grate C= 0.600 Limited to weir flow at low heads
#2	Primary	132.75'	9.6" Horiz. Orifice/Grate C= 0.600 Limited to weir flow at low heads
#3	Primary	133.46'	12.0" Horiz. Orifice/Grate C= 0.600 Limited to weir flow at low heads

Primary OutFlow Max=1.13 cfs @ 13.26 hrs HW=132.75' (Free Discharge)
 1=Orifice/Grate (Orifice Controls 1.13 cfs @ 6.38 fps)
 2=Orifice/Grate (Weir Controls 0.00 cfs @ 0.18 fps)
 3=Orifice/Grate (Controls 0.00 cfs)

Pond 3: Pond

Hydrograph

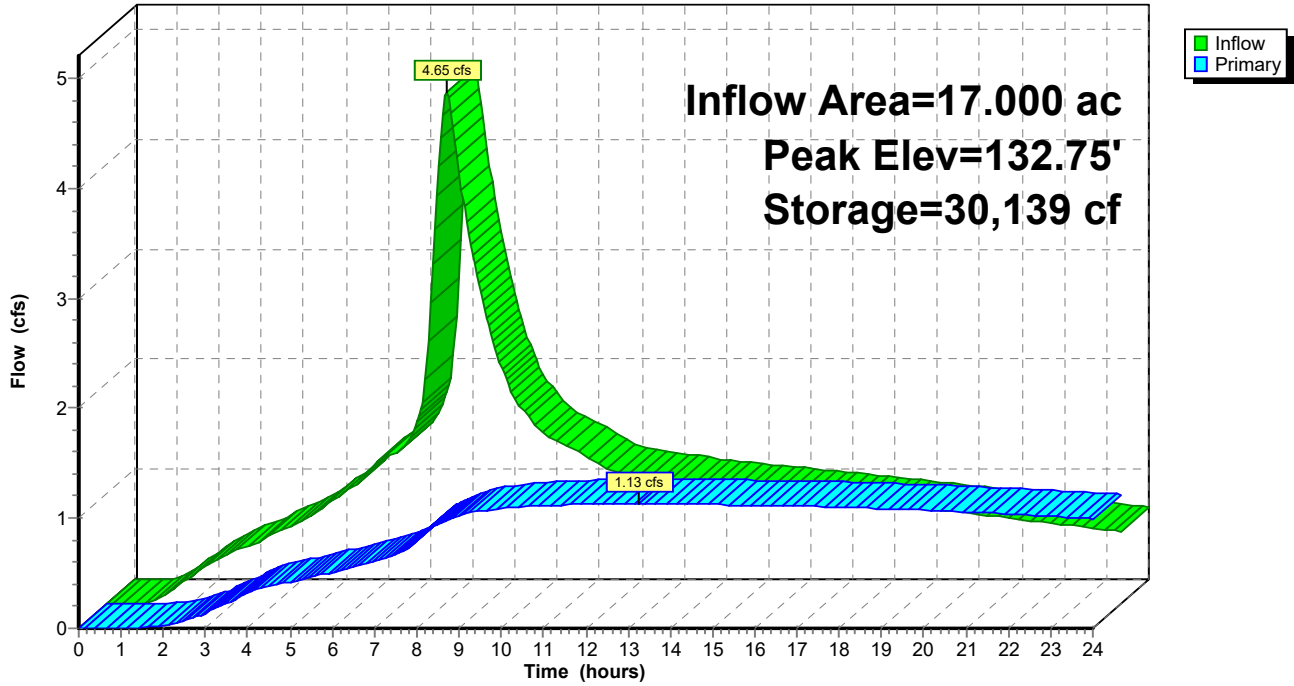

AsaLockwood

Prepared by Microsoft

HydroCAD® 10.10-7a s/n 12389 © 2021 HydroCAD Software Solutions LLC

Type IA 24-hr 10-year Rainfall=3.30"

Printed 5/1/2022

Page 9

Time span=0.00-24.00 hrs, dt=0.05 hrs, 481 points
Runoff by SBUH method, Split Pervious/Imperv.
Reach routing by Stor-Ind+Trans method - Pond routing by Stor-Ind method

Subcatchment1: UndevelopedSite

Runoff Area=17.000 ac 1.59% Impervious Runoff Depth>1.23"
Flow Length=900' Slope=0.0500 '/' Tc=29.1 min CN=76/98 Runoff=2.88 cfs 1.742 af

Subcatchment2: DevelopedSite

Runoff Area=17.000 ac 60.71% Impervious Runoff Depth>2.27"
Flow Length=1,325' Tc=25.6 min CN=74/98 Runoff=7.06 cfs 3.219 af

Pond 3: Pond

Peak Elev=133.18' Storage=38,152 cf Inflow=7.06 cfs 3.219 af
Outflow=2.84 cfs 2.534 af

Total Runoff Area = 34.000 ac Runoff Volume = 4.960 af Average Runoff Depth = 1.75"
68.85% Pervious = 23.410 ac 31.15% Impervious = 10.590 ac

Summary for Subcatchment 1: Undeveloped Site

Runoff = 2.88 cfs @ 8.12 hrs, Volume= 1.742 af, Depth> 1.23"

Runoff by SBUH method, Split Pervious/Imperv., Time Span= 0.00-24.00 hrs, dt= 0.05 hrs
Type IA 24-hr 10-year Rainfall=3.30"

Area (ac)	CN	Description
* 16.730	76	Woods, Good, HSG C
* 0.270	98	Existing Lockwood
17.000	76	Weighted Average
16.730	76	98.41% Pervious Area
0.270	98	1.59% Impervious Area

Tc (min)	Length (feet)	Slope (ft/ft)	Velocity (ft/sec)	Capacity (cfs)	Description
17.2	100	0.0500	0.10		Sheet Flow, sheet flow
11.9	800	0.0500	1.12		Woods: Light underbrush n= 0.400 P2= 2.40" Shallow Concentrated Flow, Concentrated Flow
29.1	900	Total			Woodland Kv= 5.0 fps

Subcatchment 1: Undeveloped Site

Hydrograph

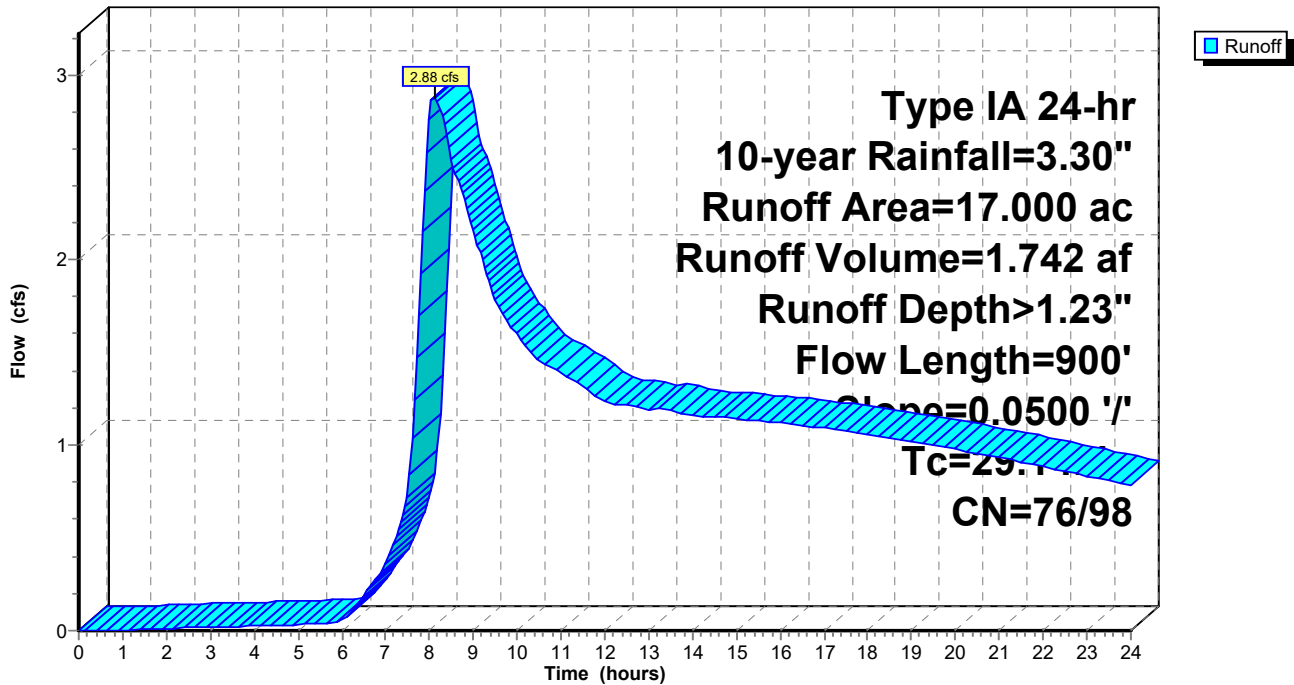

Summary for Subcatchment 2: Developed Site

[47] Hint: Peak is 26743% of capacity of segment #2

[47] Hint: Peak is 198% of capacity of segment #3

Runoff = 7.06 cfs @ 8.04 hrs, Volume= 3.219 af, Depth> 2.27"
 Routed to Pond 3 : Pond

Runoff by SBUH method, Split Pervious/Imperv., Time Span= 0.00-24.00 hrs, dt= 0.05 hrs
 Type IA 24-hr 10-year Rainfall=3.30"

Area (ac)	CN	Description
3.740	98	Paved roads w/curbs & sewers, HSG C
6.680	74	>75% Grass cover, Good, HSG C
* 6.020	98	Lot Impervious Area (maximum)
* 0.560	98	Detention Pond Surface Area
17.000	89	Weighted Average
6.680	74	39.29% Pervious Area
10.320	98	60.71% Impervious Area

Tc (min)	Length (feet)	Slope (ft/ft)	Velocity (ft/sec)	Capacity (cfs)	Description
13.5	125	0.0200	0.15		Sheet Flow, Lawn Sheet Flow Grass: Short n= 0.150 P2= 2.40"
8.4	200	0.0300	0.40	0.03	Parabolic Channel, Gutter W=0.50' D=0.20' Area=0.1 sf Perim=0.7' n= 0.140
3.7	1,000	0.0100	4.54	3.56	Pipe Channel, CMP_Round 12" 12.0" Round Area= 0.8 sf Perim= 3.1' r= 0.25' n= 0.013
25.6	1,325	Total			

Subcatchment 2: Developed Site

Hydrograph

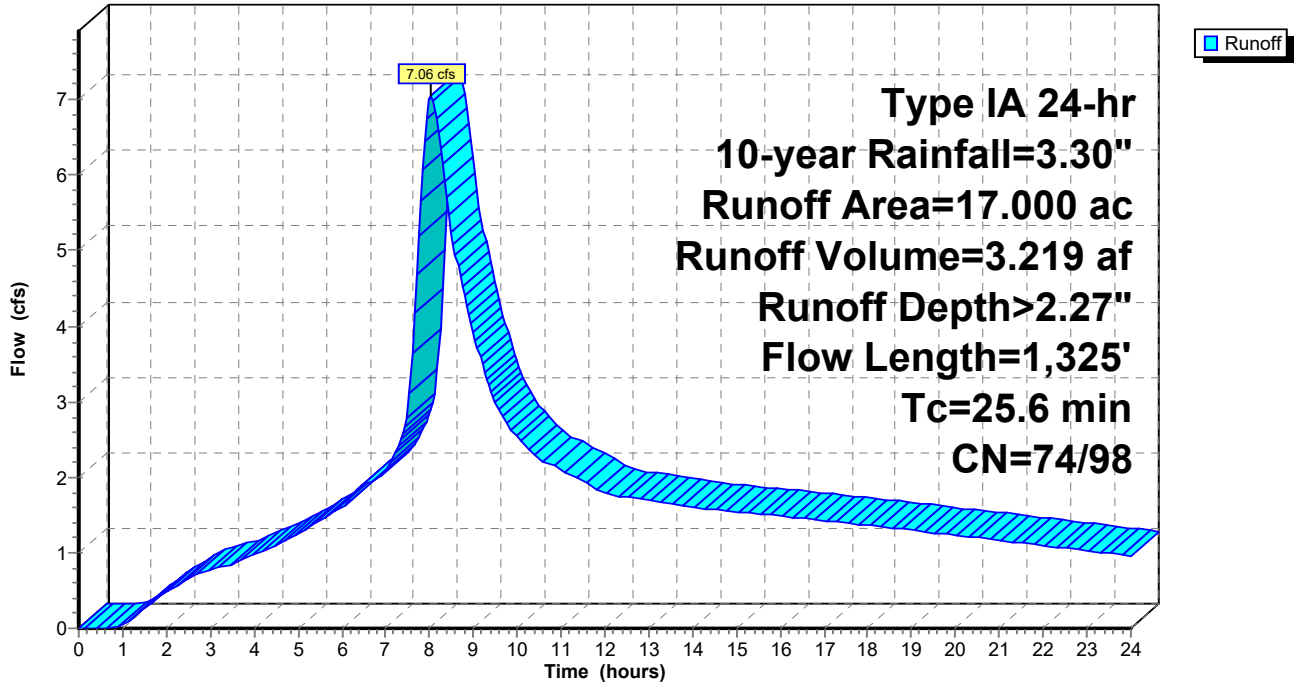

Summary for Pond 3: Pond

Inflow Area = 17.000 ac, 60.71% Impervious, Inflow Depth > 2.27" for 10-year event
 Inflow = 7.06 cfs @ 8.04 hrs, Volume= 3.219 af
 Outflow = 2.84 cfs @ 9.63 hrs, Volume= 2.534 af, Atten= 60%, Lag= 95.4 min
 Primary = 2.84 cfs @ 9.63 hrs, Volume= 2.534 af

Routing by Stor-Ind method, Time Span= 0.00-24.00 hrs, dt= 0.05 hrs
 Peak Elev= 133.18' @ 9.63 hrs Surf.Area= 19,231 sf Storage= 38,152 cf

Plug-Flow detention time= 252.4 min calculated for 2.534 af (79% of inflow)
 Center-of-Mass det. time= 116.1 min (831.3 - 715.2)

Volume	Invert	Avail.Storage	Storage Description
#1	131.00'	54,524 cf	Custom Stage Data (Prismatic) Listed below (Recalc)

Elevation (feet)	Surf.Area (sq-ft)	Inc.Store (cubic-feet)	Cum.Store (cubic-feet)
131.00	15,853	0	0
132.00	17,369	16,611	16,611
133.00	18,942	18,156	34,767
134.00	20,572	19,757	54,524

Device	Routing	Invert	Outlet Devices
#1	Primary	131.00'	5.7" Horiz. Orifice/Grate C= 0.600 Limited to weir flow at low heads
#2	Primary	132.75'	9.6" Horiz. Orifice/Grate C= 0.600 Limited to weir flow at low heads
#3	Primary	133.46'	12.0" Horiz. Orifice/Grate C= 0.600 Limited to weir flow at low heads

Primary OutFlow Max=2.84 cfs @ 9.63 hrs HW=133.18' (Free Discharge)
 1=Orifice/Grate (Orifice Controls 1.26 cfs @ 7.10 fps)
 2=Orifice/Grate (Orifice Controls 1.58 cfs @ 3.15 fps)
 3=Orifice/Grate (Controls 0.00 cfs)

Pond 3: Pond

Hydrograph

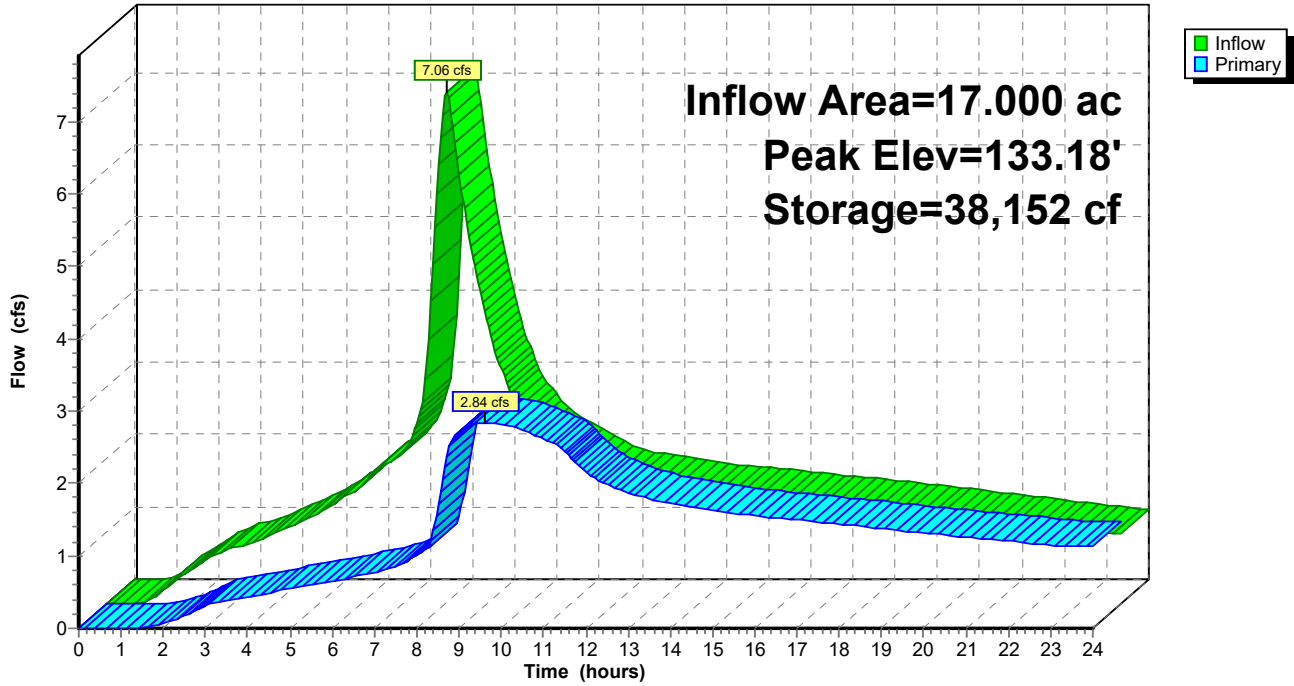

AsaLockwood

Prepared by Microsoft

HydroCAD® 10.10-7a s/n 12389 © 2021 HydroCAD Software Solutions LLC

Type IA 24-hr 25-year Rainfall=3.80"

Printed 5/1/2022

Page 15

Time span=0.00-24.00 hrs, dt=0.05 hrs, 481 points
Runoff by SBUH method, Split Pervious/Imperv.
Reach routing by Stor-Ind+Trans method - Pond routing by Stor-Ind method

Subcatchment1: UndevelopedSite

Runoff Area=17.000 ac 1.59% Impervious Runoff Depth>1.59"
Flow Length=900' Slope=0.0500 '/' Tc=29.1 min CN=76/98 Runoff=4.03 cfs 2.254 af

Subcatchment2: DevelopedSite

Runoff Area=17.000 ac 60.71% Impervious Runoff Depth>2.71"
Flow Length=1,325' Tc=25.6 min CN=74/98 Runoff=8.47 cfs 3.835 af

Pond 3: Pond

Peak Elev=133.50' Storage=44,404 cf Inflow=8.47 cfs 3.835 af
Outflow=3.52 cfs 3.123 af

Total Runoff Area = 34.000 ac Runoff Volume = 6.089 af Average Runoff Depth = 2.15"
68.85% Pervious = 23.410 ac 31.15% Impervious = 10.590 ac

Summary for Subcatchment 1: Undeveloped Site

Runoff = 4.03 cfs @ 8.08 hrs, Volume= 2.254 af, Depth> 1.59"

Runoff by SBUH method, Split Pervious/Imperv., Time Span= 0.00-24.00 hrs, dt= 0.05 hrs
Type IA 24-hr 25-year Rainfall=3.80"

Area (ac)	CN	Description
* 16.730	76	Woods, Good, HSG C
* 0.270	98	Exisiting Lockwood
17.000	76	Weighted Average
16.730	76	98.41% Pervious Area
0.270	98	1.59% Impervious Area

Tc (min)	Length (feet)	Slope (ft/ft)	Velocity (ft/sec)	Capacity (cfs)	Description
17.2	100	0.0500	0.10		Sheet Flow, sheet flow
					Woods: Light underbrush n= 0.400 P2= 2.40"
11.9	800	0.0500	1.12		Shallow Concentrated Flow, Concentrated Flow
					Woodland Kv= 5.0 fps
29.1	900	Total			

Subcatchment 1: Undeveloped Site

Hydrograph

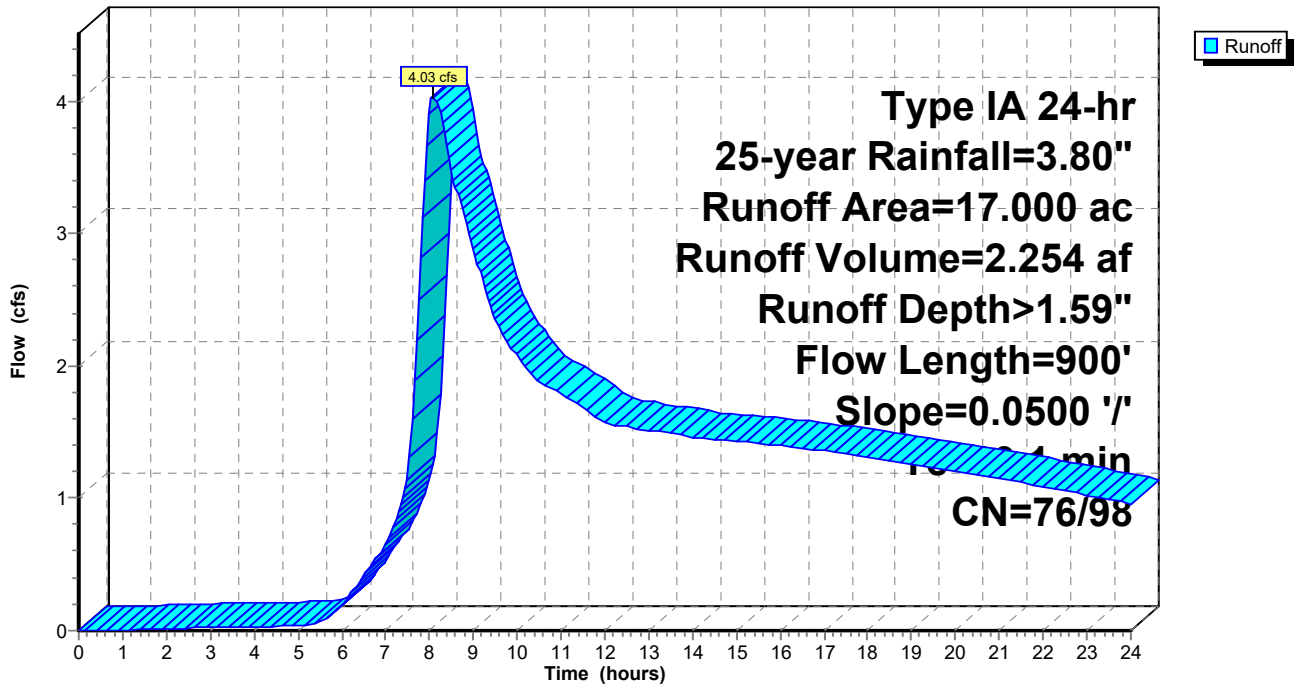

Summary for Subcatchment 2: Developed Site

[47] Hint: Peak is 32077% of capacity of segment #2

[47] Hint: Peak is 238% of capacity of segment #3

Runoff = 8.47 cfs @ 8.04 hrs, Volume= 3.835 af, Depth> 2.71"
 Routed to Pond 3 : Pond

Runoff by SBUH method, Split Pervious/Imperv., Time Span= 0.00-24.00 hrs, dt= 0.05 hrs
 Type IA 24-hr 25-year Rainfall=3.80"

Area (ac)	CN	Description
3.740	98	Paved roads w/curbs & sewers, HSG C
6.680	74	>75% Grass cover, Good, HSG C
* 6.020	98	Lot Impervious Area (maximum)
* 0.560	98	Detention Pond Surface Area
17.000	89	Weighted Average
6.680	74	39.29% Pervious Area
10.320	98	60.71% Impervious Area

Tc (min)	Length (feet)	Slope (ft/ft)	Velocity (ft/sec)	Capacity (cfs)	Description
13.5	125	0.0200	0.15		Sheet Flow, Lawn Sheet Flow Grass: Short n= 0.150 P2= 2.40"
8.4	200	0.0300	0.40	0.03	Parabolic Channel, Gutter W=0.50' D=0.20' Area=0.1 sf Perim=0.7' n= 0.140
3.7	1,000	0.0100	4.54	3.56	Pipe Channel, CMP_Round 12" 12.0" Round Area= 0.8 sf Perim= 3.1' r= 0.25' n= 0.013
25.6	1,325	Total			

Subcatchment 2: Developed Site

Hydrograph

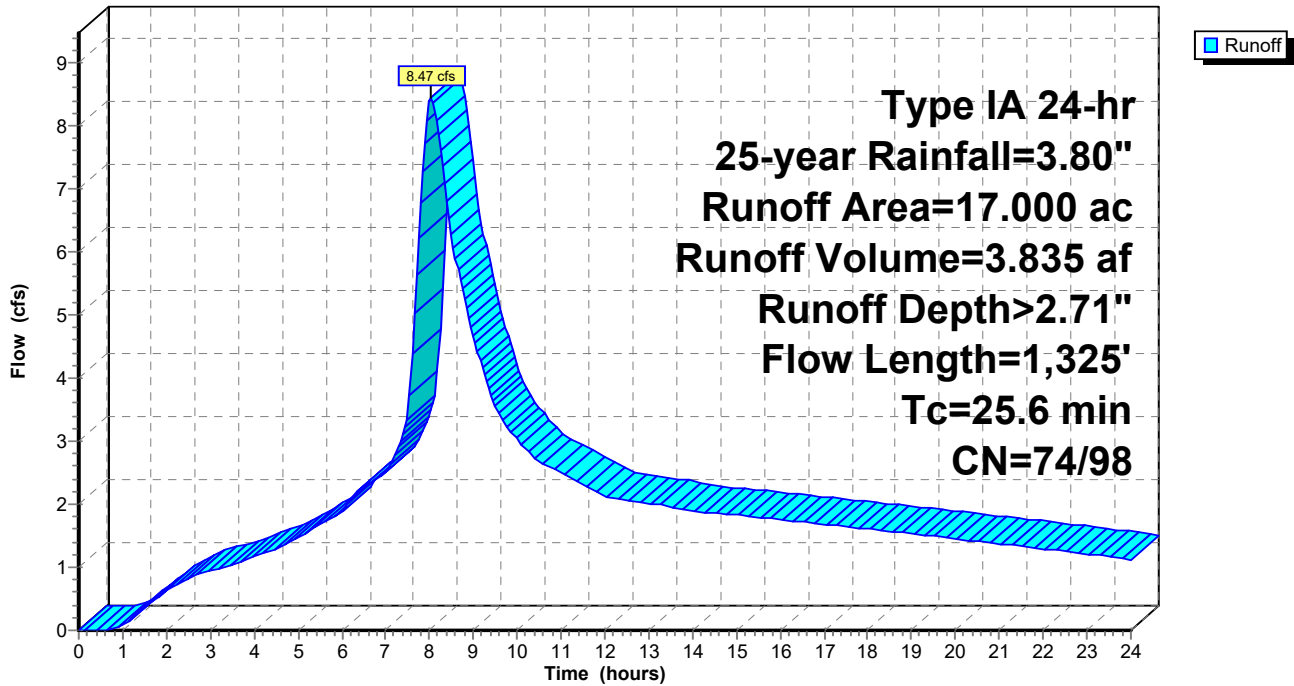

Summary for Pond 3: Pond

Inflow Area = 17.000 ac, 60.71% Impervious, Inflow Depth > 2.71" for 25-year event
 Inflow = 8.47 cfs @ 8.04 hrs, Volume= 3.835 af
 Outflow = 3.52 cfs @ 9.52 hrs, Volume= 3.123 af, Atten= 58%, Lag= 89.2 min
 Primary = 3.52 cfs @ 9.52 hrs, Volume= 3.123 af

Routing by Stor-Ind method, Time Span= 0.00-24.00 hrs, dt= 0.05 hrs
 Peak Elev= 133.50' @ 9.52 hrs Surf.Area= 19,754 sf Storage= 44,404 cf

Plug-Flow detention time= 230.5 min calculated for 3.116 af (81% of inflow)
 Center-of-Mass det. time= 109.9 min (822.2 - 712.4)

Volume	Invert	Avail.Storage	Storage Description
#1	131.00'	54,524 cf	Custom Stage Data (Prismatic) Listed below (Recalc)

Elevation (feet)	Surf.Area (sq-ft)	Inc.Store (cubic-feet)	Cum.Store (cubic-feet)
131.00	15,853	0	0
132.00	17,369	16,611	16,611
133.00	18,942	18,156	34,767
134.00	20,572	19,757	54,524

Device	Routing	Invert	Outlet Devices
#1	Primary	131.00'	5.7" Horiz. Orifice/Grate C= 0.600 Limited to weir flow at low heads
#2	Primary	132.75'	9.6" Horiz. Orifice/Grate C= 0.600 Limited to weir flow at low heads
#3	Primary	133.46'	12.0" Horiz. Orifice/Grate C= 0.600 Limited to weir flow at low heads

Primary OutFlow Max=3.52 cfs @ 9.52 hrs HW=133.50' (Free Discharge)
 1=Orifice/Grate (Orifice Controls 1.35 cfs @ 7.61 fps)
 2=Orifice/Grate (Orifice Controls 2.09 cfs @ 4.16 fps)
 3=Orifice/Grate (Weir Controls 0.08 cfs @ 0.64 fps)

Pond 3: Pond

Hydrograph

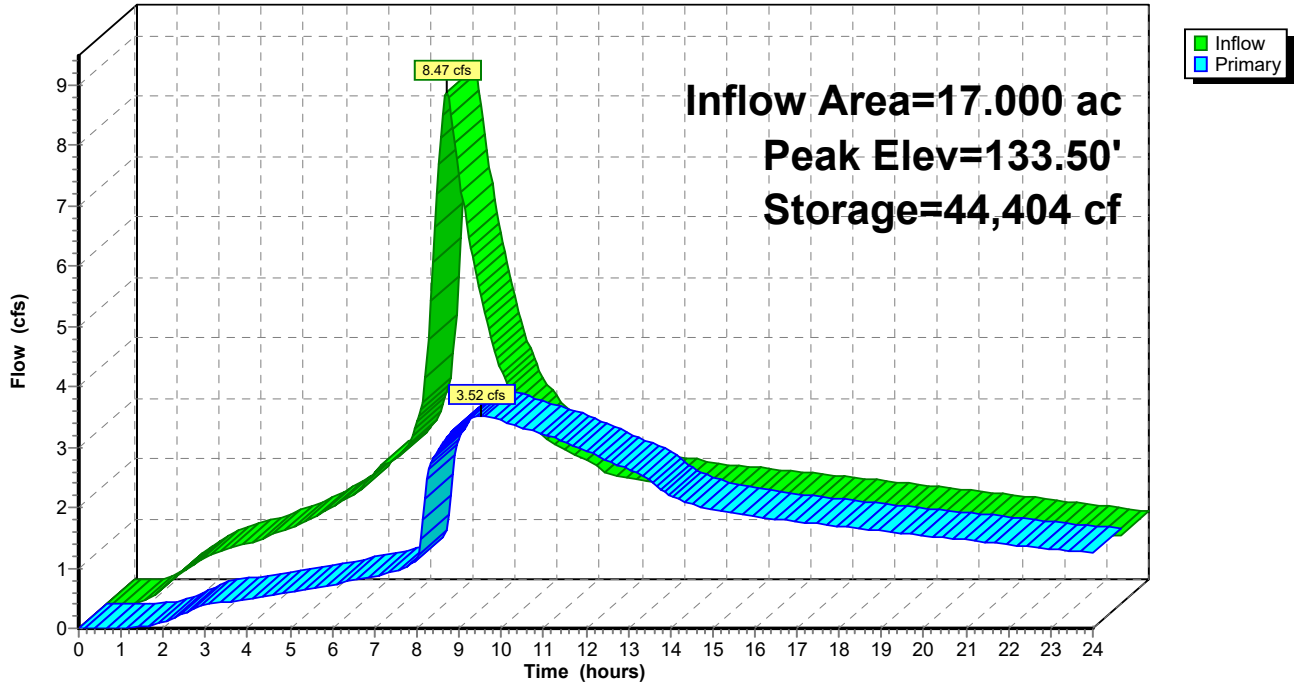

AsaLockwood

Prepared by Microsoft

HydroCAD® 10.10-7a s/n 12389 © 2021 HydroCAD Software Solutions LLC

Type IA 24-hr 100-year Rainfall=4.50"

Printed 5/1/2022

Page 21

Time span=0.00-24.00 hrs, dt=0.05 hrs, 481 points
Runoff by SBUH method, Split Pervious/Imperv.
Reach routing by Stor-Ind+Trans method - Pond routing by Stor-Ind method

Subcatchment1: UndevelopedSite Runoff Area=17.000 ac 1.59% Impervious Runoff Depth>2.13"
Flow Length=900' Slope=0.0500 '/' Tc=29.1 min CN=76/98 Runoff=5.80 cfs 3.017 af

Subcatchment2: DevelopedSite Runoff Area=17.000 ac 60.71% Impervious Runoff Depth>3.33"
Flow Length=1,325' Tc=25.6 min CN=74/98 Runoff=10.50 cfs 4.717 af

Pond 3: Pond Peak Elev=133.78' Storage=50,130 cf Inflow=10.50 cfs 4.717 af
Outflow=5.79 cfs 3.979 af

Total Runoff Area = 34.000 ac Runoff Volume = 7.734 af Average Runoff Depth = 2.73"
68.85% Pervious = 23.410 ac 31.15% Impervious = 10.590 ac

Summary for Subcatchment 1: Undeveloped Site

Runoff = 5.80 cfs @ 8.07 hrs, Volume= 3.017 af, Depth> 2.13"

Runoff by SBUH method, Split Pervious/Imperv., Time Span= 0.00-24.00 hrs, dt= 0.05 hrs
 Type IA 24-hr 100-year Rainfall=4.50"

Area (ac)	CN	Description
* 16.730	76	Woods, Good, HSG C
* 0.270	98	Existing Lockwood
17.000	76	Weighted Average
16.730	76	98.41% Pervious Area
0.270	98	1.59% Impervious Area

Tc (min)	Length (feet)	Slope (ft/ft)	Velocity (ft/sec)	Capacity (cfs)	Description
17.2	100	0.0500	0.10		Sheet Flow, sheet flow
					Woods: Light underbrush n= 0.400 P2= 2.40"
11.9	800	0.0500	1.12		Shallow Concentrated Flow, Concentrated Flow
					Woodland Kv= 5.0 fps
29.1	900	Total			

Subcatchment 1: Undeveloped Site

Hydrograph

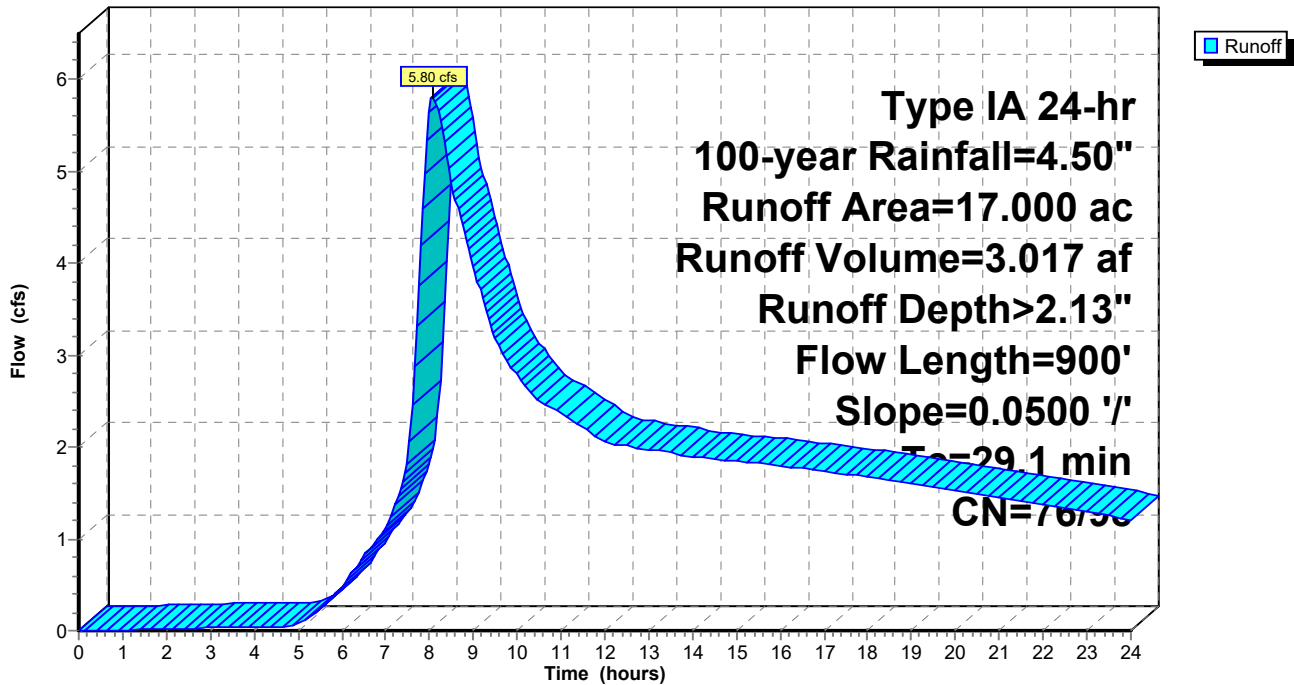

Summary for Subcatchment 2: Developed Site

[47] Hint: Peak is 39762% of capacity of segment #2

[47] Hint: Peak is 295% of capacity of segment #3

Runoff = 10.50 cfs @ 8.04 hrs, Volume= 4.717 af, Depth> 3.33"
 Routed to Pond 3 : Pond

Runoff by SBUH method, Split Pervious/Imperv., Time Span= 0.00-24.00 hrs, dt= 0.05 hrs
 Type IA 24-hr 100-year Rainfall=4.50"

Area (ac)	CN	Description
3.740	98	Paved roads w/curbs & sewers, HSG C
6.680	74	>75% Grass cover, Good, HSG C
* 6.020	98	Lot Impervious Area (maximum)
* 0.560	98	Detention Pond Surface Area
17.000	89	Weighted Average
6.680	74	39.29% Pervious Area
10.320	98	60.71% Impervious Area

Tc (min)	Length (feet)	Slope (ft/ft)	Velocity (ft/sec)	Capacity (cfs)	Description
13.5	125	0.0200	0.15		Sheet Flow, Lawn Sheet Flow Grass: Short n= 0.150 P2= 2.40"
8.4	200	0.0300	0.40	0.03	Parabolic Channel, Gutter W=0.50' D=0.20' Area=0.1 sf Perim=0.7' n= 0.140
3.7	1,000	0.0100	4.54	3.56	Pipe Channel, CMP_Round 12" 12.0" Round Area= 0.8 sf Perim= 3.1' r= 0.25' n= 0.013
25.6	1,325	Total			

Subcatchment 2: Developed Site

Hydrograph

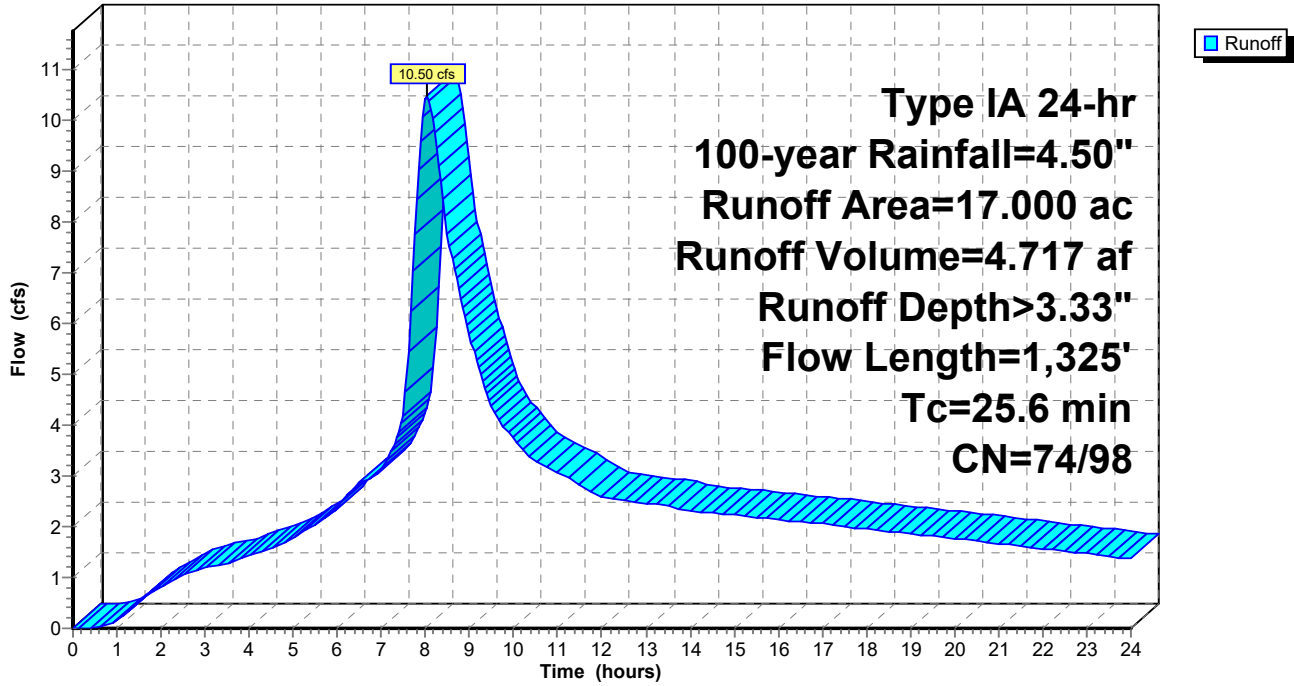

Summary for Pond 3: Pond

Inflow Area = 17.000 ac, 60.71% Impervious, Inflow Depth > 3.33" for 100-year event
 Inflow = 10.50 cfs @ 8.04 hrs, Volume= 4.717 af
 Outflow = 5.79 cfs @ 9.00 hrs, Volume= 3.979 af, Atten= 45%, Lag= 57.7 min
 Primary = 5.79 cfs @ 9.00 hrs, Volume= 3.979 af

Routing by Stor-Ind method, Time Span= 0.00-24.00 hrs, dt= 0.05 hrs
 Peak Elev= 133.78' @ 9.00 hrs Surf.Area= 20,221 sf Storage= 50,130 cf

Plug-Flow detention time= 205.1 min calculated for 3.970 af (84% of inflow)
 Center-of-Mass det. time= 101.5 min (810.3 - 708.8)

Volume	Invert	Avail.Storage	Storage Description
#1	131.00'	54,524 cf	Custom Stage Data (Prismatic) Listed below (Recalc)

Elevation (feet)	Surf.Area (sq-ft)	Inc.Store (cubic-feet)	Cum.Store (cubic-feet)
131.00	15,853	0	0
132.00	17,369	16,611	16,611
133.00	18,942	18,156	34,767
134.00	20,572	19,757	54,524

Device	Routing	Invert	Outlet Devices
#1	Primary	131.00'	5.7" Horiz. Orifice/Grate C= 0.600 Limited to weir flow at low heads
#2	Primary	132.75'	9.6" Horiz. Orifice/Grate C= 0.600 Limited to weir flow at low heads
#3	Primary	133.46'	12.0" Horiz. Orifice/Grate C= 0.600 Limited to weir flow at low heads

Primary OutFlow Max=5.79 cfs @ 9.00 hrs HW=133.78' (Free Discharge)
 1=Orifice/Grate (Orifice Controls 1.42 cfs @ 8.03 fps)
 2=Orifice/Grate (Orifice Controls 2.46 cfs @ 4.90 fps)
 3=Orifice/Grate (Weir Controls 1.90 cfs @ 1.86 fps)

Pond 3: Pond

Hydrograph

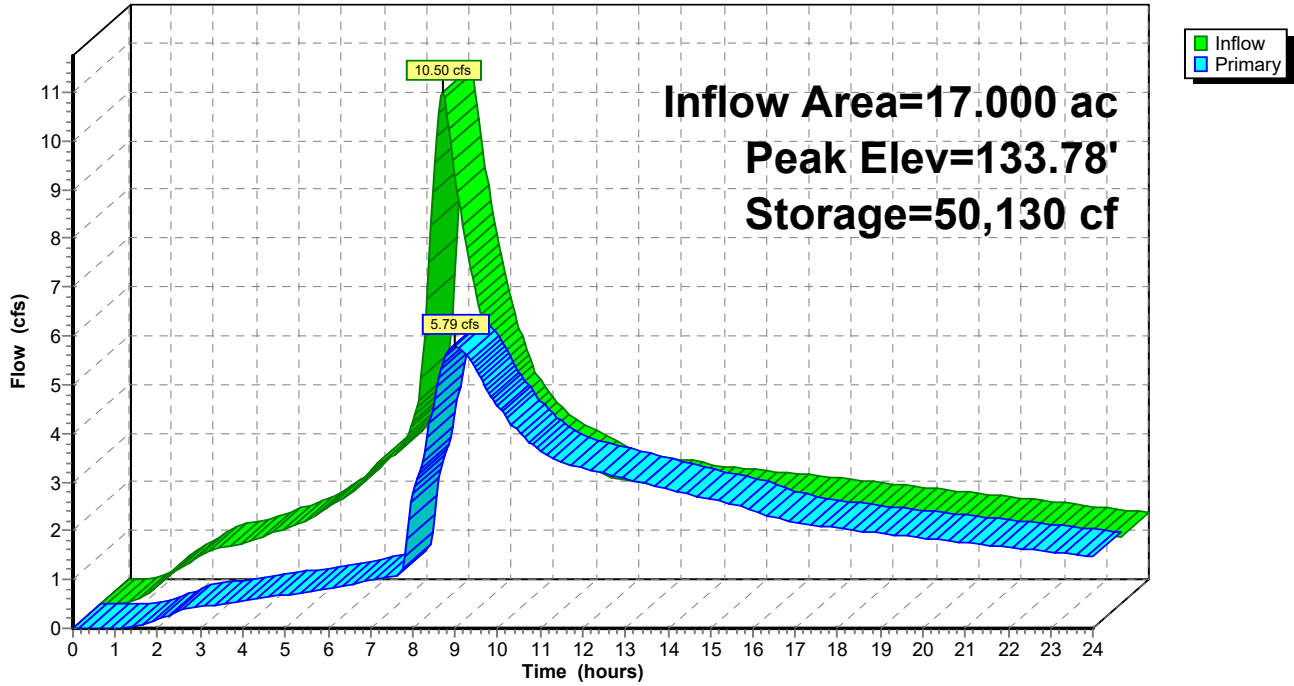

AsaLockwood

Prepared by Microsoft

HydroCAD® 10.10-7a s/n 12389 © 2021 HydroCAD Software Solutions LLC

Type IA 24-hr WQ Rainfall=1.54"

Printed 5/1/2022

Page 27

Time span=0.00-24.00 hrs, dt=0.05 hrs, 481 points
Runoff by SBUH method, Split Pervious/Imperv.
Reach routing by Stor-Ind+Trans method - Pond routing by Stor-Ind method

Subcatchment1: UndevelopedSite Runoff Area=17.000 ac 1.59% Impervious Runoff Depth>0.21"
Flow Length=900' Slope=0.0500 '/' Tc=29.1 min CN=76/98 Runoff=0.25 cfs 0.304 af

Subcatchment2: Developed Site Runoff Area=17.000 ac 60.71% Impervious Runoff Depth>0.85"
Flow Length=1,325' Tc=25.6 min CN=74/98 Runoff=2.68 cfs 1.211 af

Pond 3: Pond Peak Elev=131.86' Storage=14,120 cf Inflow=2.68 cfs 1.211 af
Outflow=0.79 cfs 1.051 af

Total Runoff Area = 34.000 ac Runoff Volume = 1.516 af Average Runoff Depth = 0.53"
68.85% Pervious = 23.410 ac 31.15% Impervious = 10.590 ac

Summary for Subcatchment 1: Undeveloped Site

Runoff = 0.25 cfs @ 17.37 hrs, Volume= 0.304 af, Depth> 0.21"

Runoff by SBUH method, Split Pervious/Imperv., Time Span= 0.00-24.00 hrs, dt= 0.05 hrs
Type IA 24-hr WQ Rainfall=1.54"

Area (ac)	CN	Description
* 16.730	76	Woods, Good, HSG C
* 0.270	98	Exisiting Lockwood
17.000	76	Weighted Average
16.730	76	98.41% Pervious Area
0.270	98	1.59% Impervious Area

Tc (min)	Length (feet)	Slope (ft/ft)	Velocity (ft/sec)	Capacity (cfs)	Description
17.2	100	0.0500	0.10		Sheet Flow, sheet flow
					Woods: Light underbrush n= 0.400 P2= 2.40"
11.9	800	0.0500	1.12		Shallow Concentrated Flow, Concentrated Flow
					Woodland Kv= 5.0 fps
29.1	900	Total			

Subcatchment 1: Undeveloped Site

Hydrograph

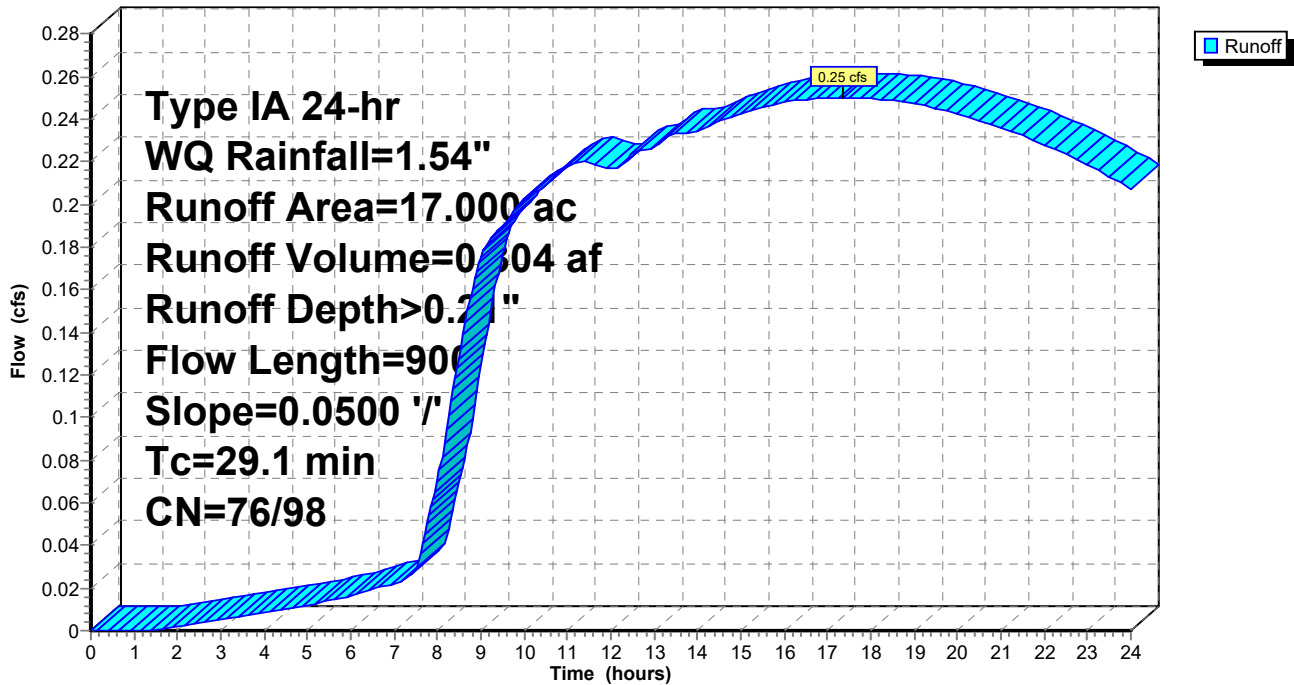

Summary for Subcatchment 2: Developed Site

[47] Hint: Peak is 10169% of capacity of segment #2

Runoff = 2.68 cfs @ 8.03 hrs, Volume= 1.211 af, Depth> 0.85"
 Routed to Pond 3 : Pond

Runoff by SBUH method, Split Pervious/Imperv., Time Span= 0.00-24.00 hrs, dt= 0.05 hrs
 Type IA 24-hr WQ Rainfall=1.54"

Area (ac)	CN	Description
3.740	98	Paved roads w/curbs & sewers, HSG C
6.680	74	>75% Grass cover, Good, HSG C
* 6.020	98	Lot Impervious Area (maximum)
* 0.560	98	Detention Pond Surface Area
17.000	89	Weighted Average
6.680	74	39.29% Pervious Area
10.320	98	60.71% Impervious Area

Tc (min)	Length (feet)	Slope (ft/ft)	Velocity (ft/sec)	Capacity (cfs)	Description
13.5	125	0.0200	0.15		Sheet Flow, Lawn Sheet Flow Grass: Short n= 0.150 P2= 2.40"
8.4	200	0.0300	0.40	0.03	Parabolic Channel, Gutter W=0.50' D=0.20' Area=0.1 sf Perim=0.7' n= 0.140
3.7	1,000	0.0100	4.54	3.56	Pipe Channel, CMP_Round 12" 12.0" Round Area= 0.8 sf Perim= 3.1' r= 0.25' n= 0.013
25.6	1,325	Total			

Subcatchment 2: Developed Site

Hydrograph

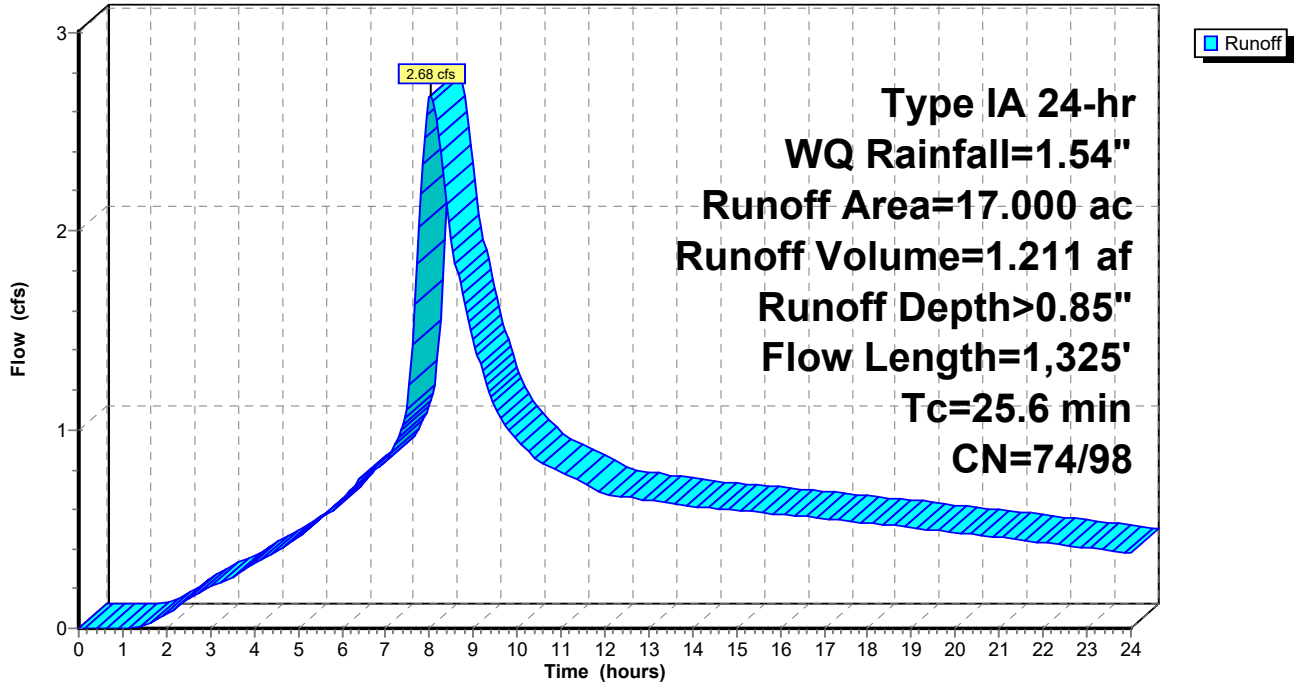

Summary for Pond 3: Pond

Inflow Area = 17.000 ac, 60.71% Impervious, Inflow Depth > 0.85" for WQ event
 Inflow = 2.68 cfs @ 8.03 hrs, Volume= 1.211 af
 Outflow = 0.79 cfs @ 11.01 hrs, Volume= 1.051 af, Atten= 71%, Lag= 178.6 min
 Primary = 0.79 cfs @ 11.01 hrs, Volume= 1.051 af

Routing by Stor-Ind method, Time Span= 0.00-24.00 hrs, dt= 0.05 hrs
 Peak Elev= 131.86' @ 11.01 hrs Surf.Area= 17,150 sf Storage= 14,120 cf

Plug-Flow detention time= 233.7 min calculated for 1.049 af (87% of inflow)
 Center-of-Mass det. time= 146.3 min (874.7 - 728.3)

Volume	Invert	Avail.Storage	Storage Description
#1	131.00'	54,524 cf	Custom Stage Data (Prismatic) Listed below (Recalc)

Elevation (feet)	Surf.Area (sq-ft)	Inc.Store (cubic-feet)	Cum.Store (cubic-feet)
131.00	15,853	0	0
132.00	17,369	16,611	16,611
133.00	18,942	18,156	34,767
134.00	20,572	19,757	54,524

Device	Routing	Invert	Outlet Devices
#1	Primary	131.00'	5.7" Horiz. Orifice/Grate C= 0.600 Limited to weir flow at low heads
#2	Primary	132.75'	9.6" Horiz. Orifice/Grate C= 0.600 Limited to weir flow at low heads
#3	Primary	133.46'	12.0" Horiz. Orifice/Grate C= 0.600 Limited to weir flow at low heads

Primary OutFlow Max=0.79 cfs @ 11.01 hrs HW=131.86' (Free Discharge)

- 1=Orifice/Grate (Orifice Controls 0.79 cfs @ 4.45 fps)
- 2=Orifice/Grate (Controls 0.00 cfs)
- 3=Orifice/Grate (Controls 0.00 cfs)

Pond 3: Pond

Hydrograph

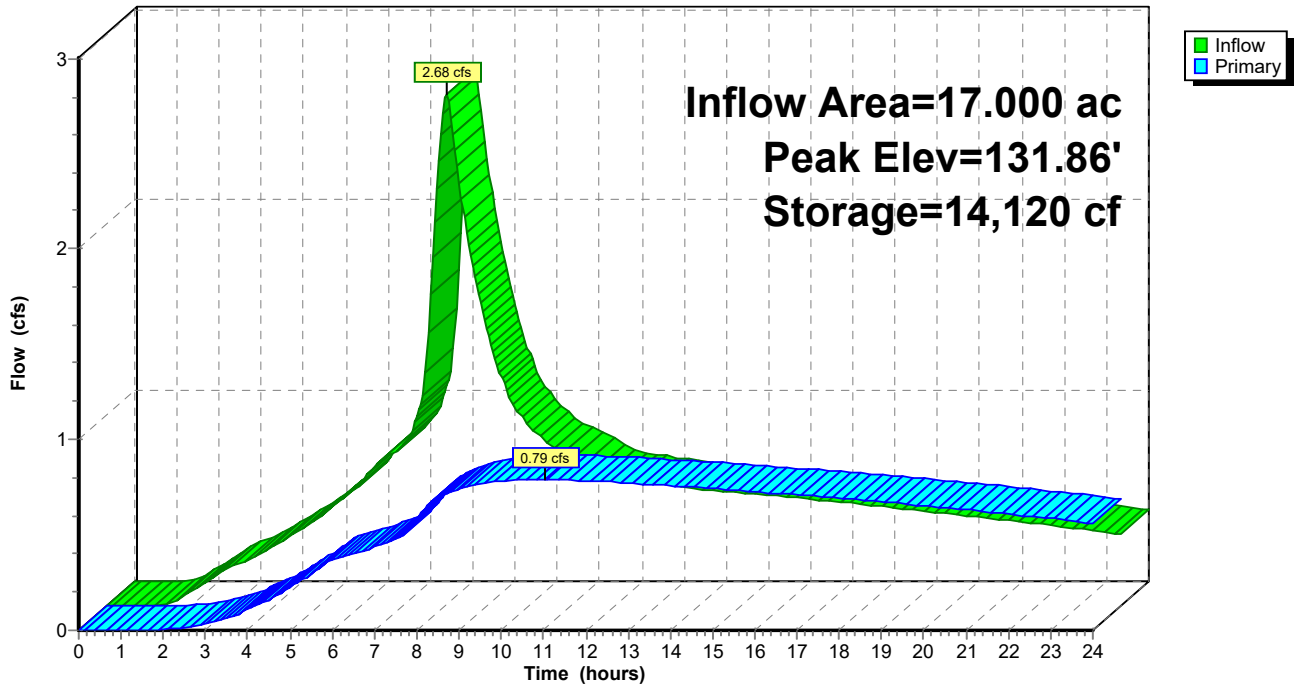

Appendix C.

Preliminary Stormwater Plans

Asa's View Subdivision

Located in the SW 1/4 of the NE 1/4 of Section 2, T4N, R1E, W.M.
La Center, Washington

Preliminary Plans

NW Consilio LLC
2410 NE 22nd Ave
Portland, OR 97212

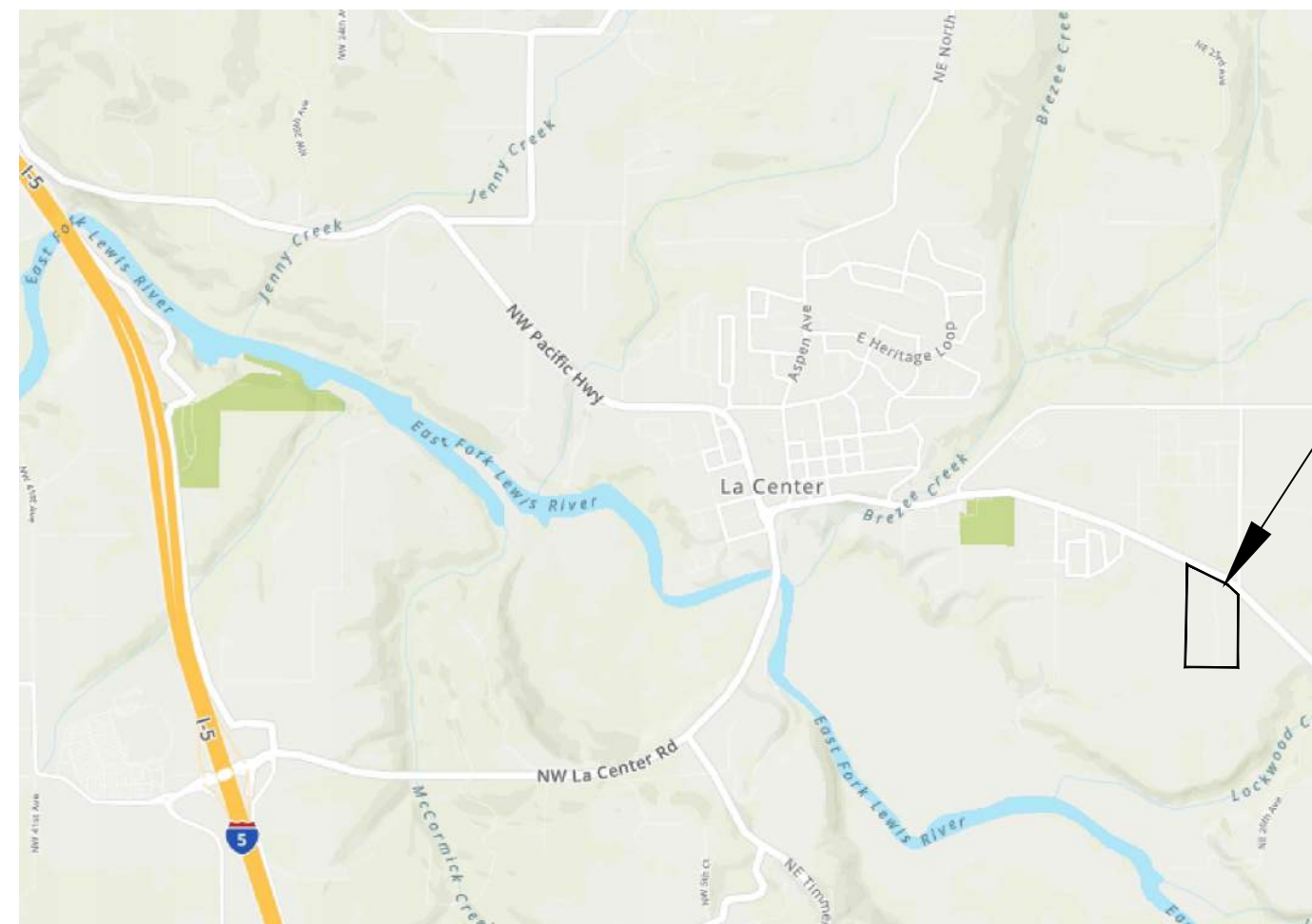

Site Location

SITE



Preliminary Plat Layout

Owner / Applicant:

Troy Johns
1004 W. 13th Street, Suite 220
Vancouver, WA 98660

Site Address

2313 NE Lockwood Road
La Center, Washington

Parcel Numbers

Lot 39: 209064-000 and
Lot 102: 209121-000

Civil Engineer:

NW Consilio LLC
2410 NE 22nd Ave
Portland, OR 97212
(503) 415-0424

Lot Size

Lot 39: 7.39 acres
Lot 102: 9.08 acres
Total: 16.47 acres

Proposal

The project proposes to subdivide Tax Lots 39 and 102 into 68 single-family residential lots in the LDR-7.5 zone.

The site current use is residential and agricultural with access from NE Lockwood Road via a private driveway, which also provides access to residences located south of the site.

Public park space totaling 0.25 acres (10,900 square feet) is proposed. Street lighting and landscaping will be provided as part of future submittals.

Total site area = 717,383 SF (16.47 AC)
ROW Dedication = 142,483 SF (3.27 AC)
Total Development area = 574,900 SF (13.20 AC)

Tract A and B to be owned and maintained by a home owners association. Tract A will be for storm water management and will include a blanket easement to the City of La Center for access and inspection. Tract B will contain a public park.

Setbacks

Front = 20', Side = 7.5', Street Side = 10.0', Back - 20'

Lot Coverage

Maximum Building Coverage = 35%
Maximum Impervious Surface Area = 50%

Utilities

Sanitary sewer services will be provided by the City of La Center. Connection to the existing sewer system will be to the existing Middle School pump station via an existing 8-inch diameter pipe stub west of the project site. The connection pipe will be located in a 15-foot wide public easement with vehicular access. The development proposes extension of the proposed sewer to the east side of the site in Lockwood Creek Road.

Public water supply will be provided by Clark Public Utilities. Connection to the public water system will be to the existing 12-inch waterline in Lockwood Creek Road.

Stormwater facilities for management of stormwater treatment and flow control will be located in Tract A in the southwest corner of the development.

Critical Areas

A non-jurisdictional wetland has been identified in the middle of the site covering 0.18 acres. It is identified as a Category 3 wetland.

An Oregon White Oak is located in the southeast portion of the proposed development in Tract B. The tree will be protected from park improvements. The project is not located within a designated 100-year floodplain or landslide hazard area. There are no known historic resources on site.

Index of Drawings

SHEET	DRAWING TITLE
1	COVER SHEET
2	EXISTING SITE CONDITIONS
3	PRELIMINARY PLAT - NORTH
4	PRELIMINARY PLAT - SOUTH
5	PRELIMINARY GRADING PLAN
6	PRELIMINARY STORMWATER PLAN - NORTH
7	PRELIMINARY STORMWATER PLAN - SOUTH
8	PRELIMINARY UTILITY PLAN - NORTH
9	PRELIMINARY UTILITY PLAN - SOUTH
10	ROAD IMPROVEMENT DETAILS
11	PRELIMINARY LANDSCAPE PLAN

Asa's View
COVER SHEET

NO.	DATE	REVISIONS

DRAWING SCALE:
NOT TO SCALE

DATE:
5/8/2022

SHEET NO.

1

INDEX NUMBER 1 OF 11

PRELIMINARY PLANS

Asa's View
 EXISTING SITE CONDITIONS

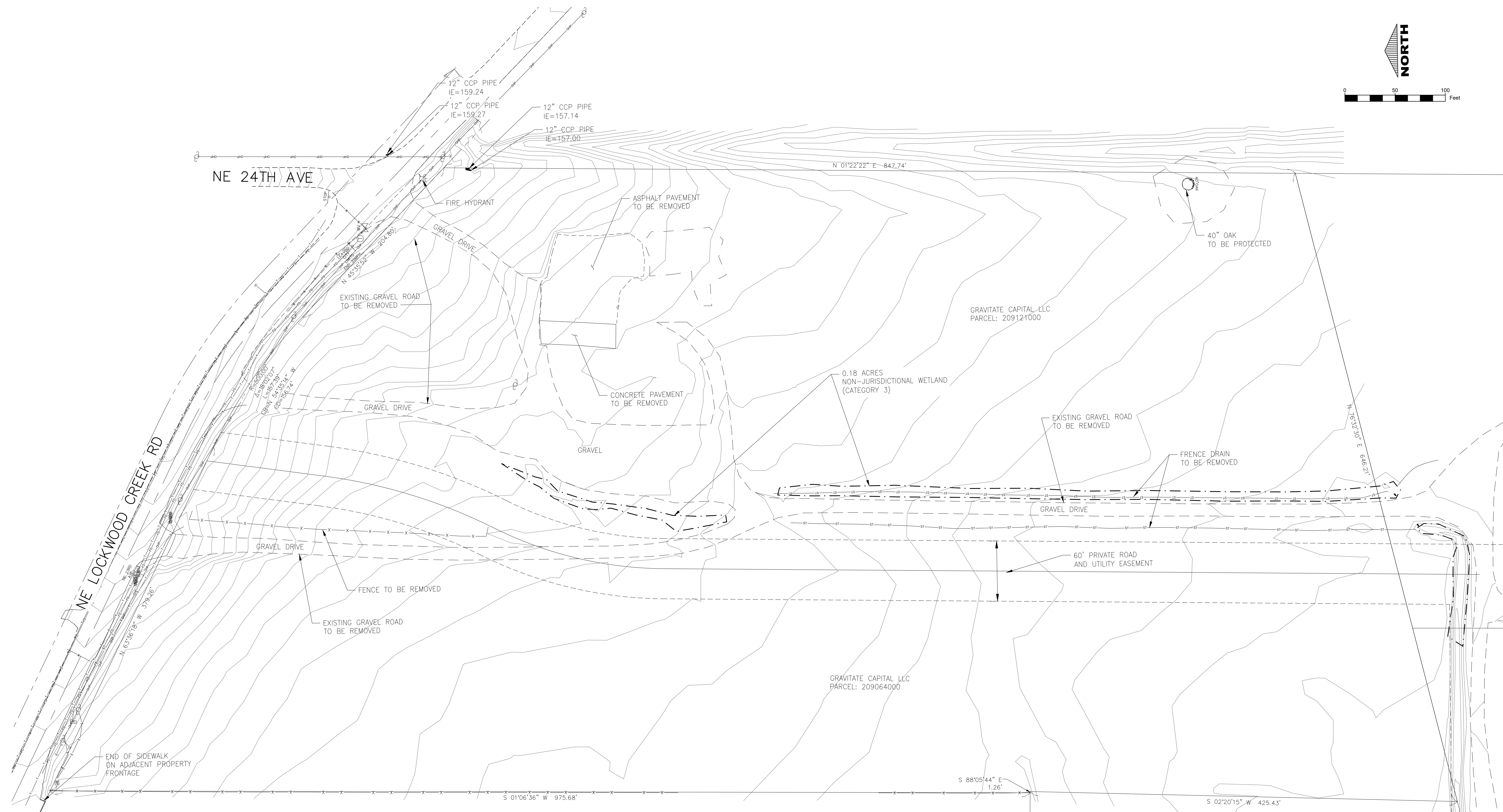
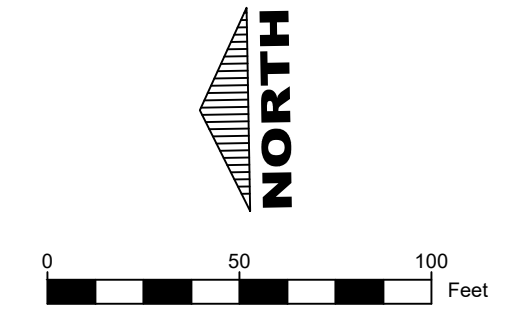

LEGEND:

- | | | | |
|--|---|--|-----------------------------------|
| | INDICATES WATER VALVE | | INDICATES BOUNDARY |
| | INDICATES FIRE HYDRANT | | INDICATES EDGE OF ASPHALT |
| | INDICATES WATER METER | | INDICATES EDGE OF CONCRETE |
| | INDICATES TRAFFIC SIGNAL POLE | | INDICATES EDGE OF GRAVEL |
| | INDICATES POWER POLE WITH DIRECTION OF OVERHEAD LINES | | INDICATES 5 FOOT INTERVAL CONTOUR |
| | INDICATES GUY ANCHOR | | INDICATES 1 FOOT INTERVAL CONTOUR |
| | INDICATES JUNCTION BOX | | INDICATES FENCE LINE |
| | INDICATES ELECTRIC METER | | INDICATES ELECTRIC LOCATE |
| | INDICATES SIGN | | INDICATES FIBER OPTIC LOCATE |
| | INDICATES MAIL BOX | | INDICATES TELEPHONE LOCATE |
| | INDICATES TELEPHONE SERVICE BOX | | INDICATES WATER LOCATE |
| | INDICATES TELEPHONE MANHOLE | | INDICATES OVER HEAD POWER |
| | INDICATES DECIDUOUS TREE WITH TRUNK DIAMETER AND TYPE | | FENCE |
- BEARINGS ARE WASHINGTON SOUTH NAD 83 SOUTH ZONE.
 ELEVATIONS ARE NAVD 88 BASED ON OPUS GPS SOLUTION TO A CONTROL POINT #1 (ELEV.142.25)

NO.	DATE	REVISIONS

DRAWING SCALE:
 AS SHOWN ON PLAN

DATE:
 5/8/2022

SHEET NO.
 2

INDEX NUMBER 2 OF 11

PRELIMINARY PLANS

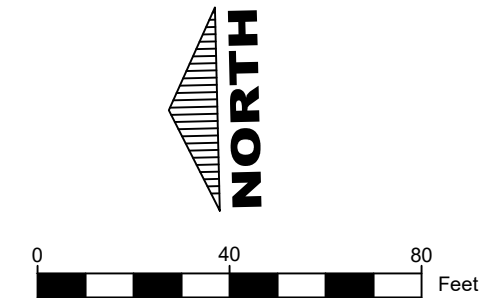
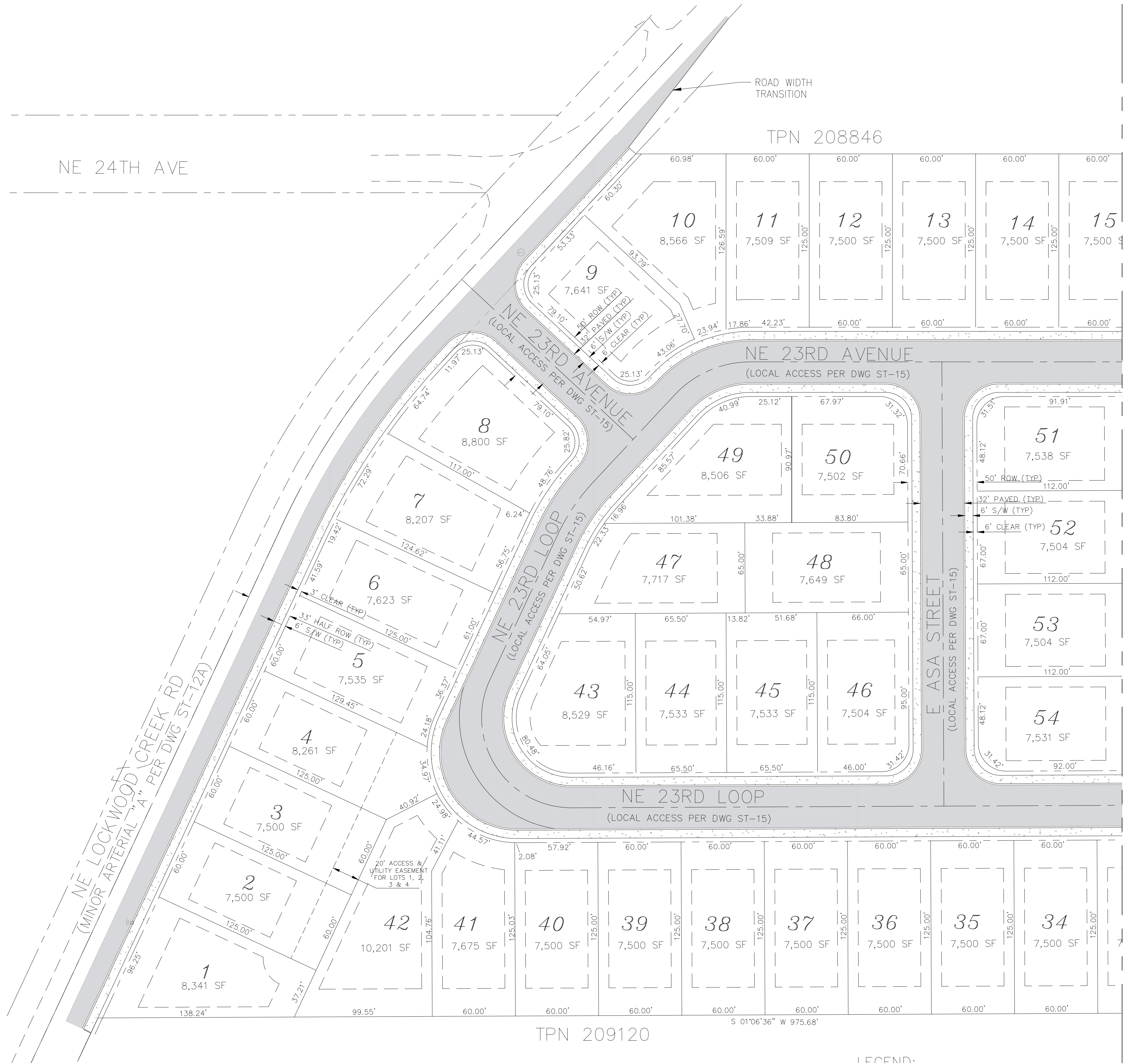

LEGEND

- RIGHT OF WAY
- PROPERTY LINE
- EASEMENT
- SETBACKS
- ROAD CENTERLINE
- [Pattern] PROPOSED ASPHALT PAVEMENT
- [Pattern] PROPOSED CONCRETE PAVEMENT
- [Pattern] PROPOSED GRAVEL ROAD

NW Consilio LLC
2410 NE 22nd Ave
Portland, OR 97212

Asa's View
PRELIMINARY PLAT - North

NO.	DATE	REVISIONS

DRAWING SCALE:
AS SHOWN ON PLAN

DATE:
5/8/2022

SHEET NO.
3

INDEX NUMBER 3 OF 11

PRELIMINARY PLANS

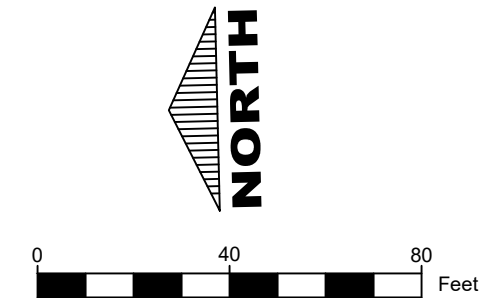

NW Consilio LLC
2410 NE 22nd Ave
Portland, OR 97212

LEGEND

- RIGHT OF WAY
- PROPERTY LINE
- - - EASEMENT
- - - SETBACKS
- ROAD CENTERLINE
- ▨ PROPOSED ASPHALT PAVEMENT
- ▨ PROPOSED CONCRETE PAVEMENT
- ▨ PROPOSED GRAVEL ROAD

MATCHLINE - SEE SHEET 3



Asa's View
PRELIMINARY PLAT

NO.	DATE	REVISIONS

DRAWING SCALE:
AS SHOWN ON PLAN
DATE:
5/8/2022
SHEET NO.
4

PRELIMINARY PLANS

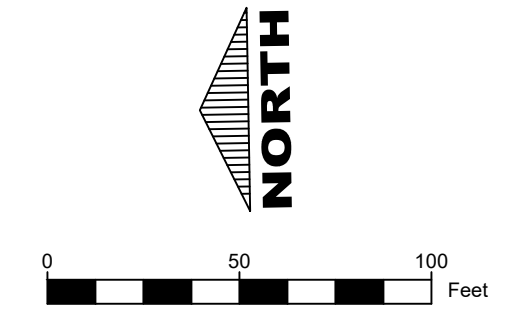

NW Consilio LLC
 2410 NE 22nd Ave
 Portland, OR 97212



Asa's View
 PRELIMINARY GRADING PLAN

NO.	DATE	REVISIONS

DRAWING SCALE:
 AS SHOWN ON PLAN
 DATE:
 5/8/2022
 SHEET NO.
 5
 INDEX NUMBER 5 OF 11

PRELIMINARY PLANS

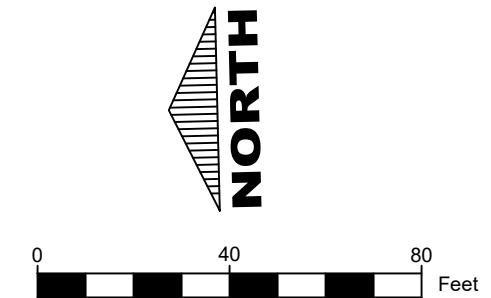

NW Consilio LLC
 2410 NE 22nd Ave
 Portland, OR 97212

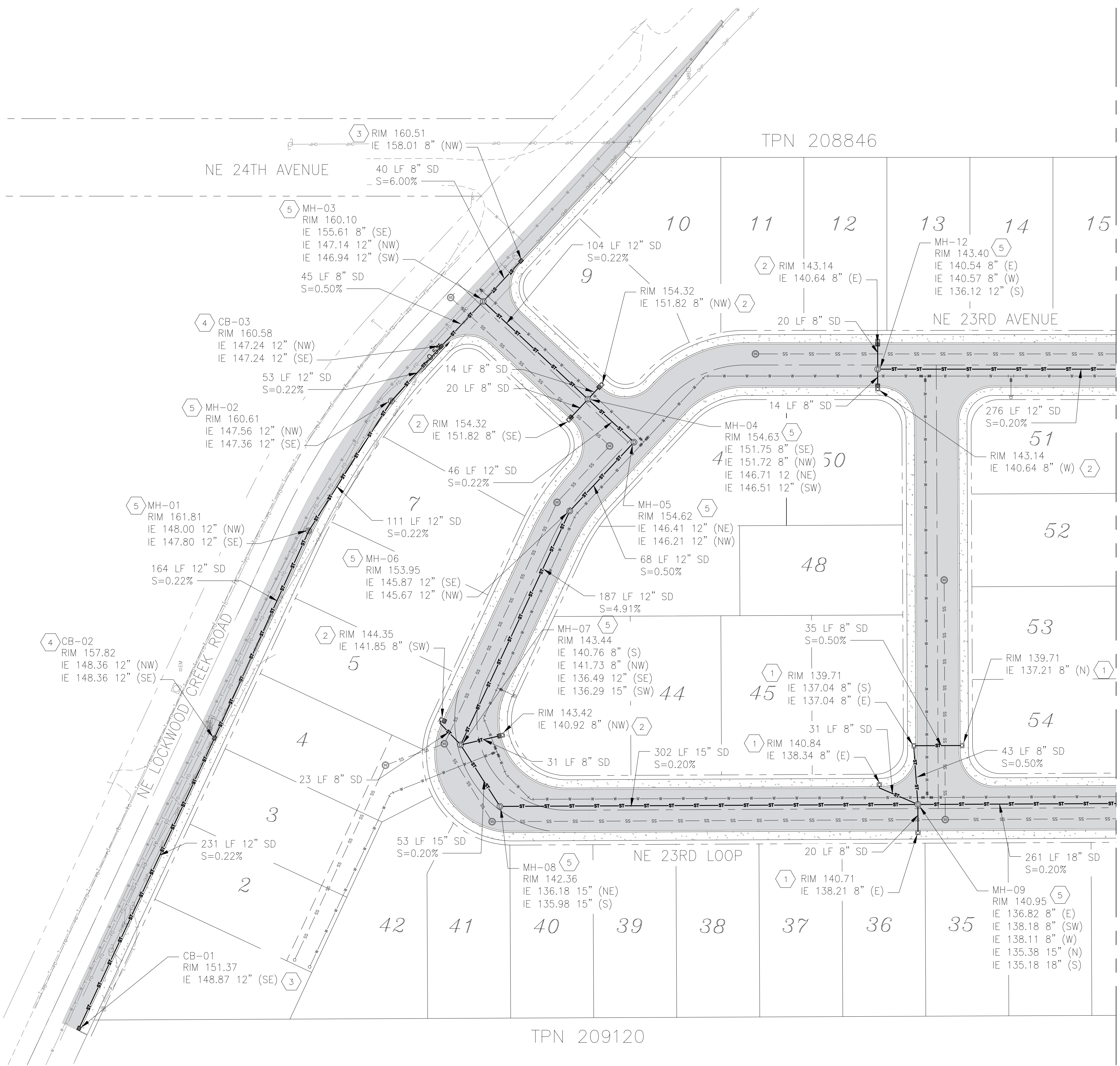

KEYNOTES

- 1 CURB INLET
PER CITY STD PLAN SM-4
- 2 COMBINATION CURB INLET
PER CITY STD PLAN SM-6
- 3 CATCH BASIN
PER CITY STD PLAN SM-5
- 4 CATCH BASIN TYPE 2, 48-INCH DIA.
WITH FRAME AND GRATE
PER WSDOT STD PLAN B-10.20-02
- 5 STORM MANHOLE, 48-INCH DIA.
PER CITY STD PLAN SM-2

Asa's View
 PRELIMINARY GRADING AND
 STORMWATER PLAN - NORTH

NO.	DATE	REVISIONS

DRAWING SCALE:
 AS SHOWN ON PLAN
 DATE:
 5/8/2022
 SHEET NO.
 6
 INDEX NUMBER 6 OF 11

PRELIMINARY PLANS

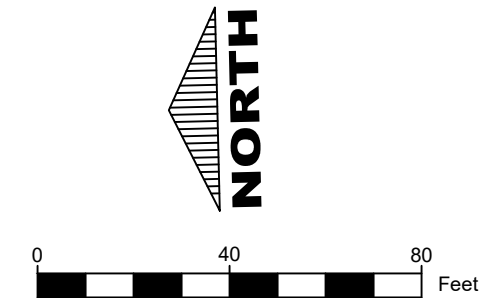

NW Consilio LLC
2410 NE 22nd Ave
Portland, OR 97212

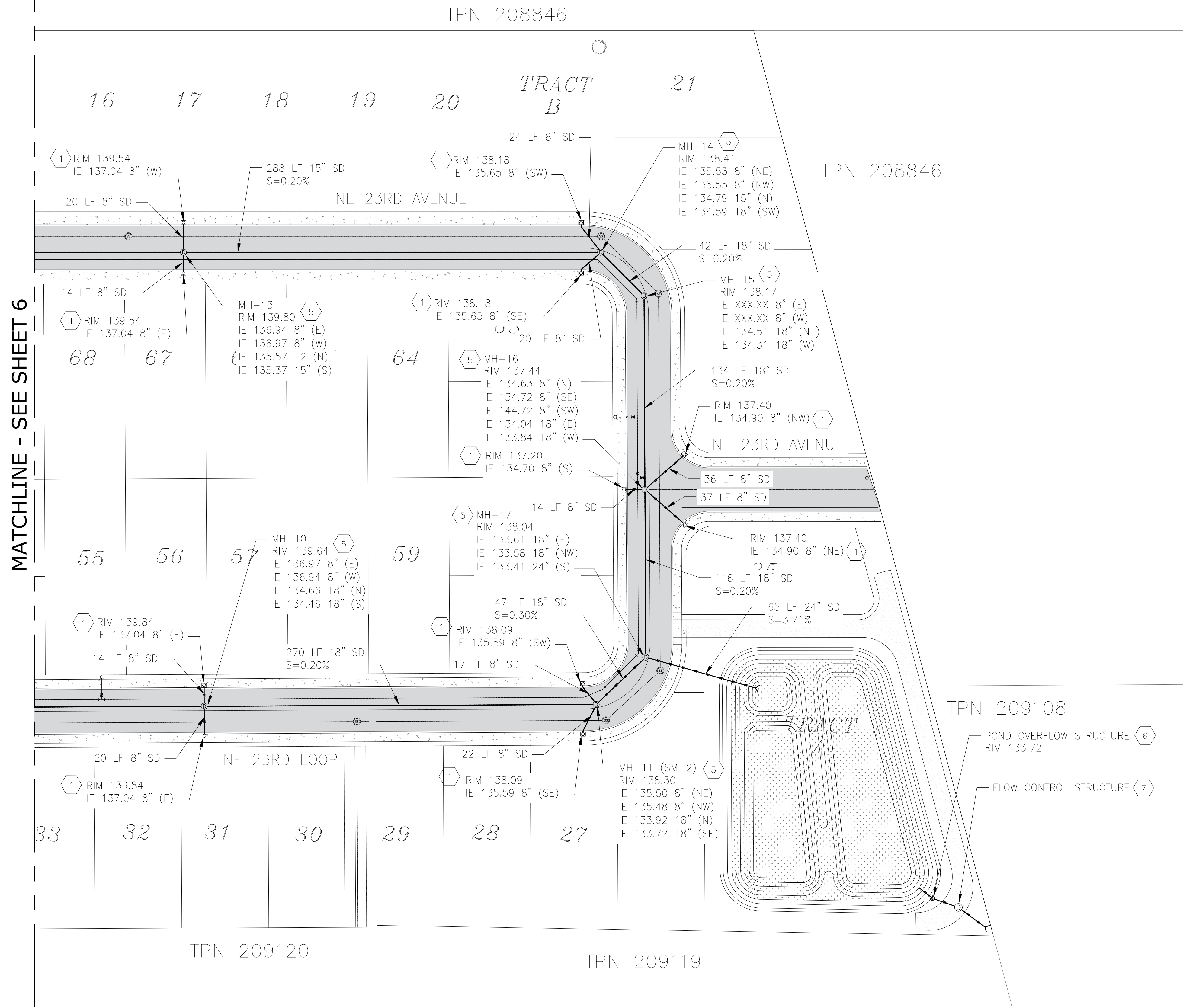

KEYNOTES

- 1 CURB INLET
PER CITY STD PLAN SM-4
- 2 COMBINATION CURB INLET
PER CITY STD PLAN SM-6
- 3 CATCH BASIN
PER CITY STD PLAN SM-5
- 4 CATCH BASIN TYPE 2, 48-INCH DIA.
WITH FRAME AND GRATE
PER WSDOT STD PLAN B-10.20-02
- 5 STORM MANHOLE, 48-INCH DIA.
PER CITY STD PLAN SM-2
- 6 SLOPED FIELD INLET
PER CITY STD PLAN SM-9
- 7 FLOW CONTROL STRUCTURE, 60-INCH DIA.
PER WSDOT STD PLAN B-10.40-02

MATCHLINE - SEE SHEET 6

Asa's View
PRELIMINARY GRADING AND
STORMWATER - SOUTH

NO.	DATE	REVISIONS

DRAWING SCALE:
AS SHOWN ON PLAN
DATE:
5/8/2022
SHEET NO.
7
INDEX NUMBER 7 OF 11

PRELIMINARY PLANS

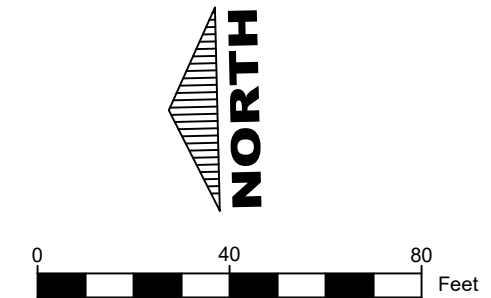

NW Consilio LLC
 2410 NE 22nd Ave
 Portland, OR 97212

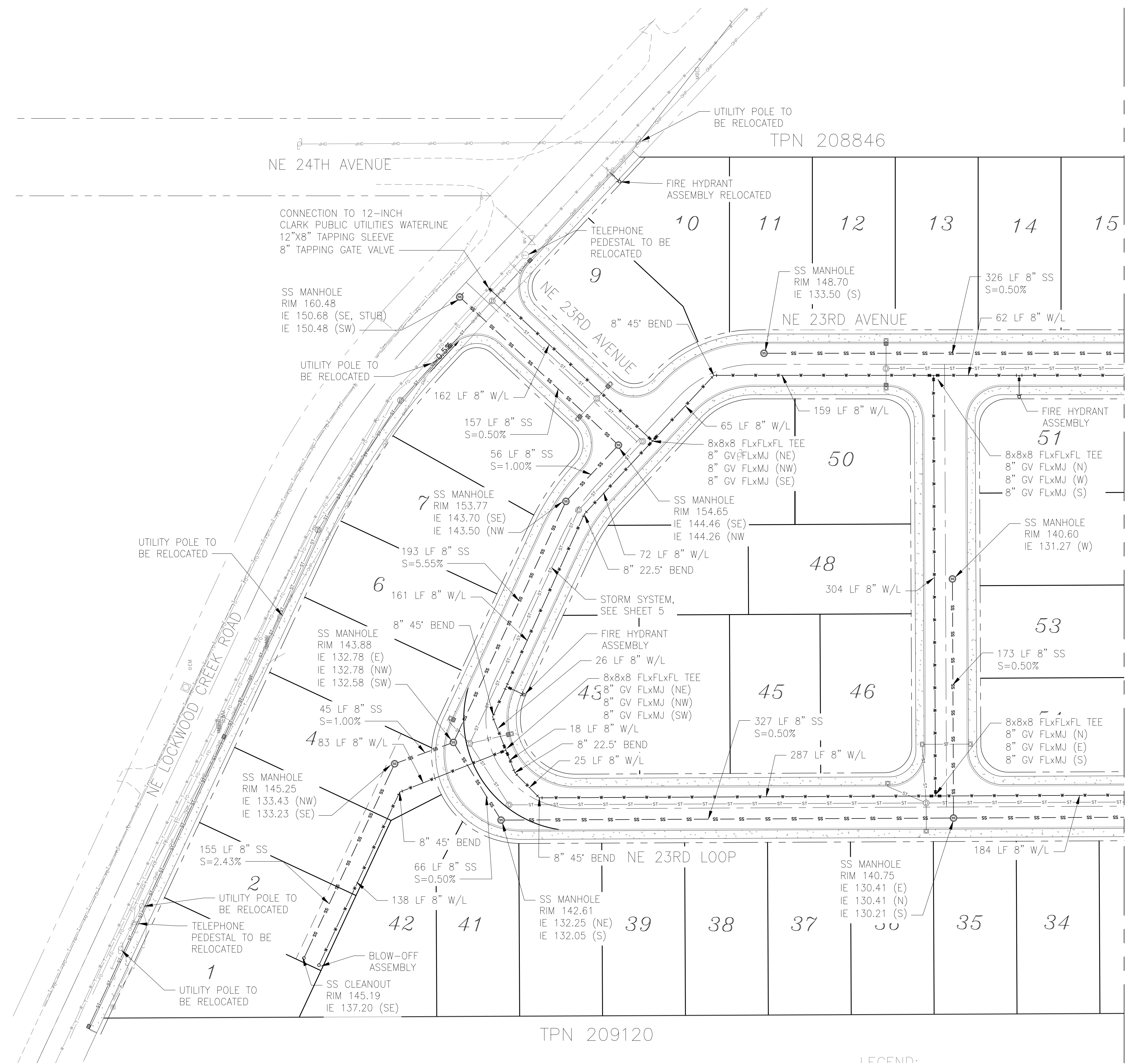

MATCHLINE - SEE SHEET 9

Asa's View
 PRELIMINARY UTILITY PLAN - NORTH

NO.	DATE	REVISIONS

DRAWING SCALE:
 AS SHOWN ON PLAN
 DATE:
 5/8/2022
 SHEET NO.
 8

PRELIMINARY PLANS

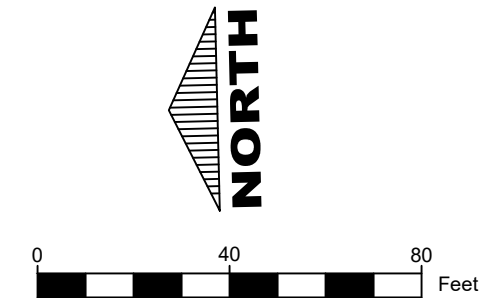

NW Consilio LLC
 2410 NE 22nd Ave
 Portland, OR 97212

Asa's View
 PRELIMINARY UTILITY PLAN - SOUTH

MATCHLINE - SEE SHEET 8

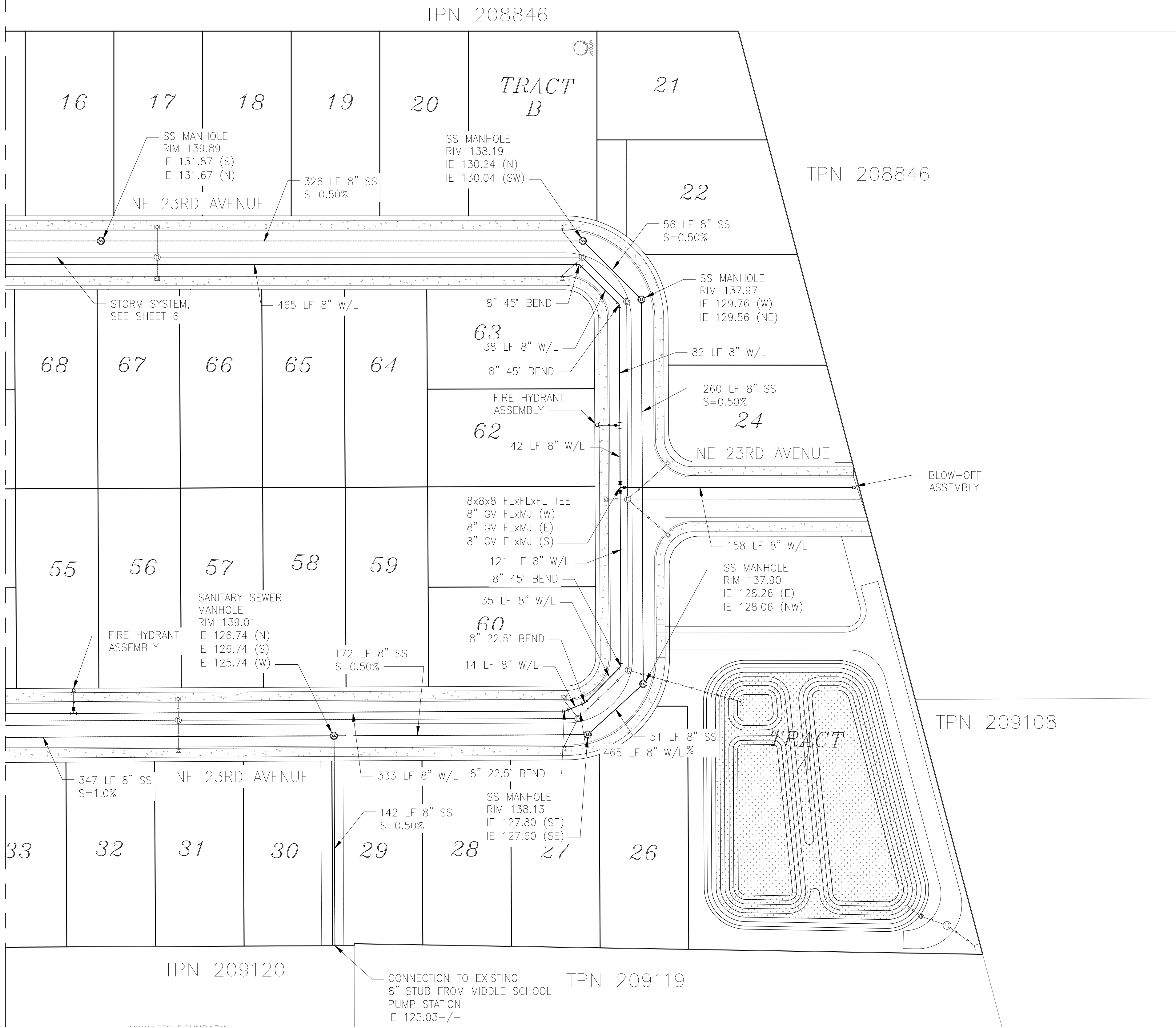

NO.	DATE	REVISIONS

DRAWING SCALE:
 AS SHOWN

DATE:
 5/8/2022

SHEET NO.
 9

INDEX NUMBER 9 OF 11

PRELIMINARY PLANS

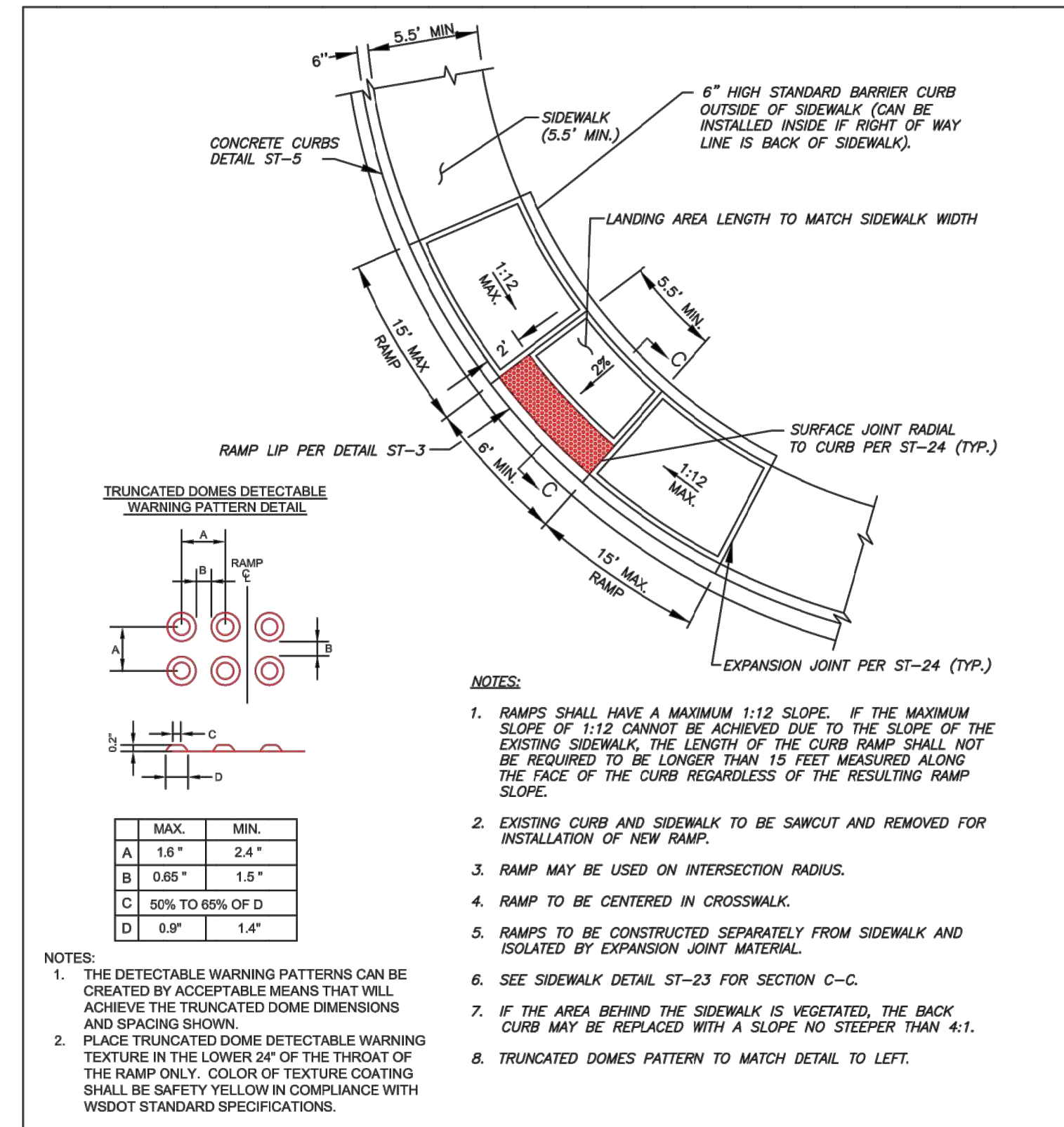

TYPE 2 CORNER RADIUS CURB RAMP		PLAN #	
	CITY OF LA CENTER APPROVED	REVISIONS:	DATE: DRAWN: DESIGNED:
	9/22/10	1	9/22/10 BES BES
CITY ENGINEER	DATE		
			ST-8A

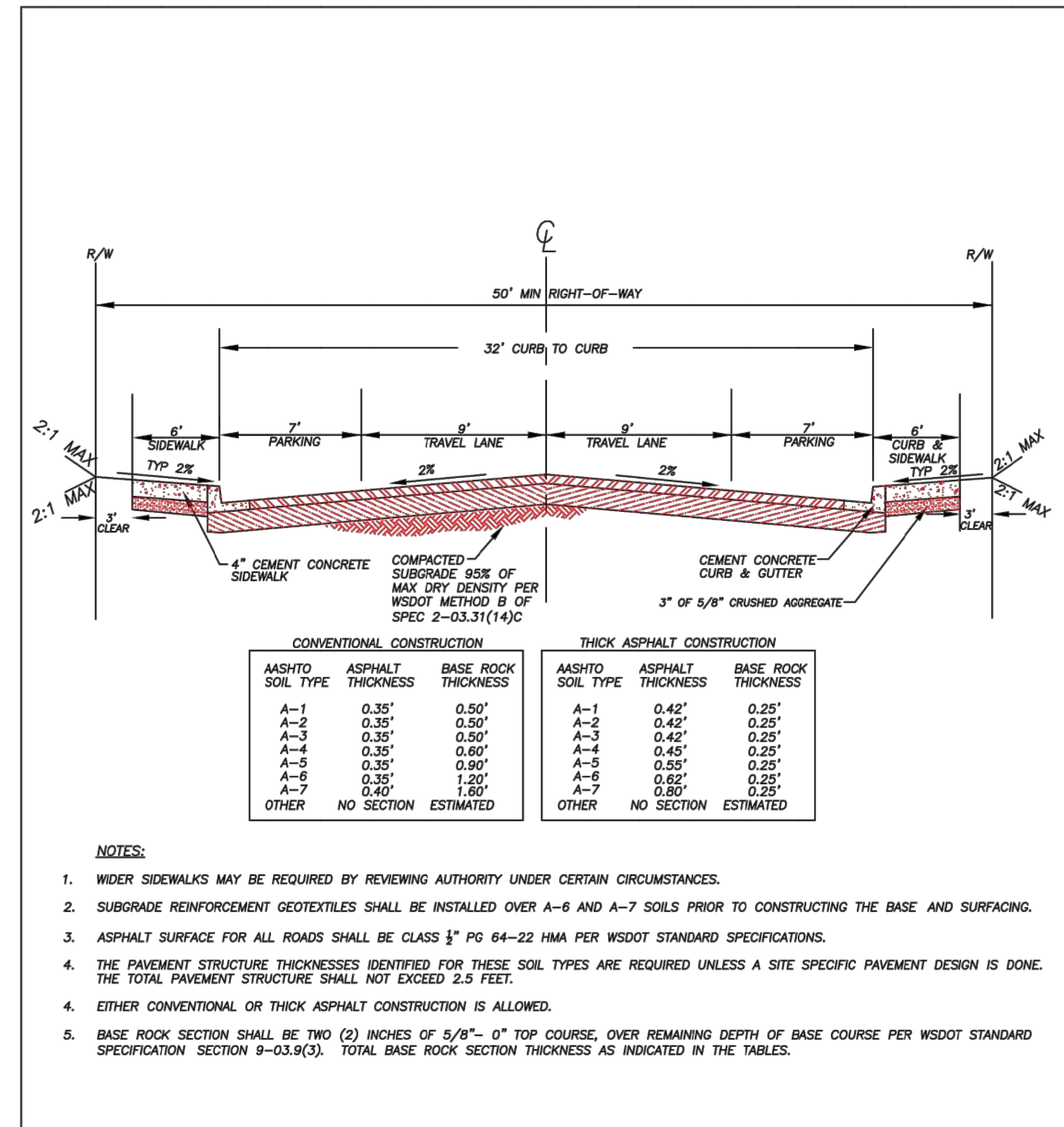

LOCAL ACCESS		PLAN #	
	CITY OF LA CENTER APPROVED	REVISIONS:	DATE: DRAWN: DESIGNED:
	9/27/10	1	9/27/10 BES BES
CITY ENGINEER	DATE		
			ST-15

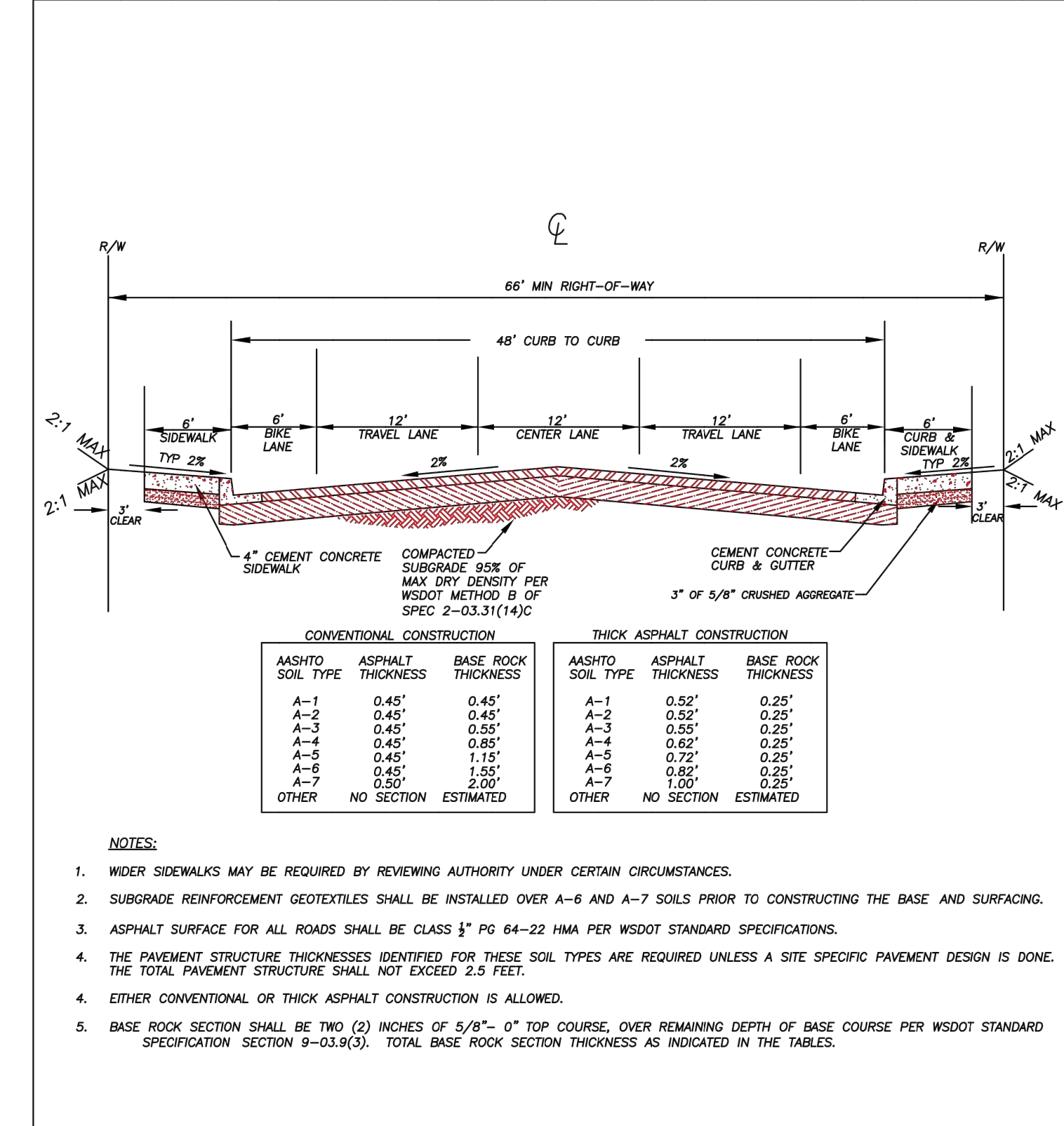

MINOR ARTERIAL "A"		PLAN #	
	CITY OF LA CENTER APPROVED	REVISIONS:	DATE: DRAWN: DESIGNED:
	8/23/16	1	8/23/16 ALC ALC
CITY ENGINEER	DATE		
			ST-12A

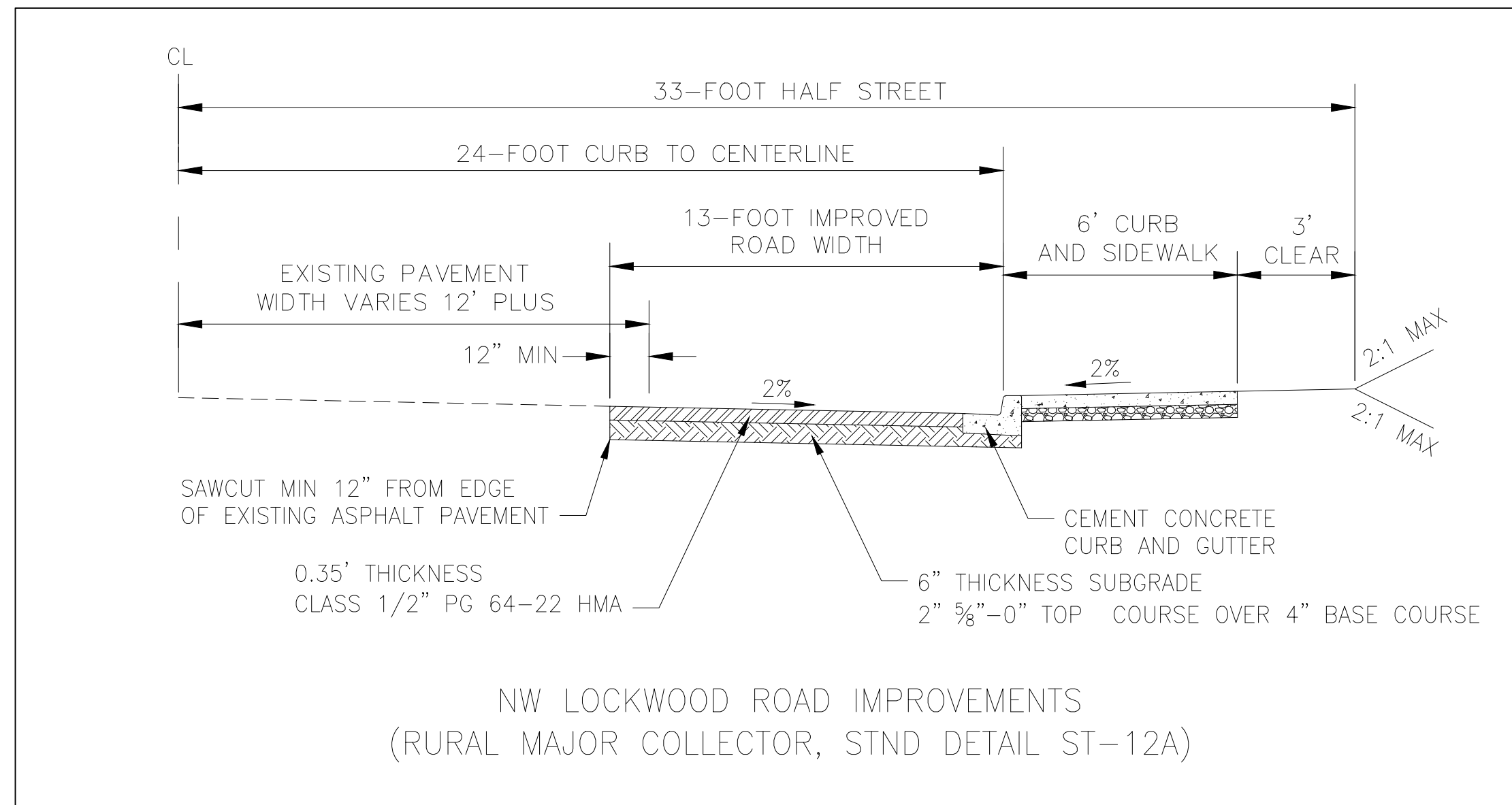

NO.	DATE	REVISIONS

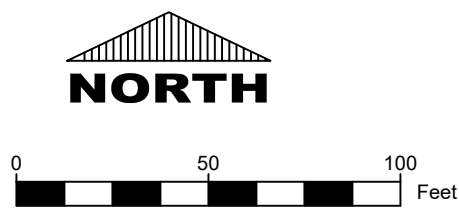

NW Consilio LLC
2410 NE 22nd Ave
Portland, OR 97212

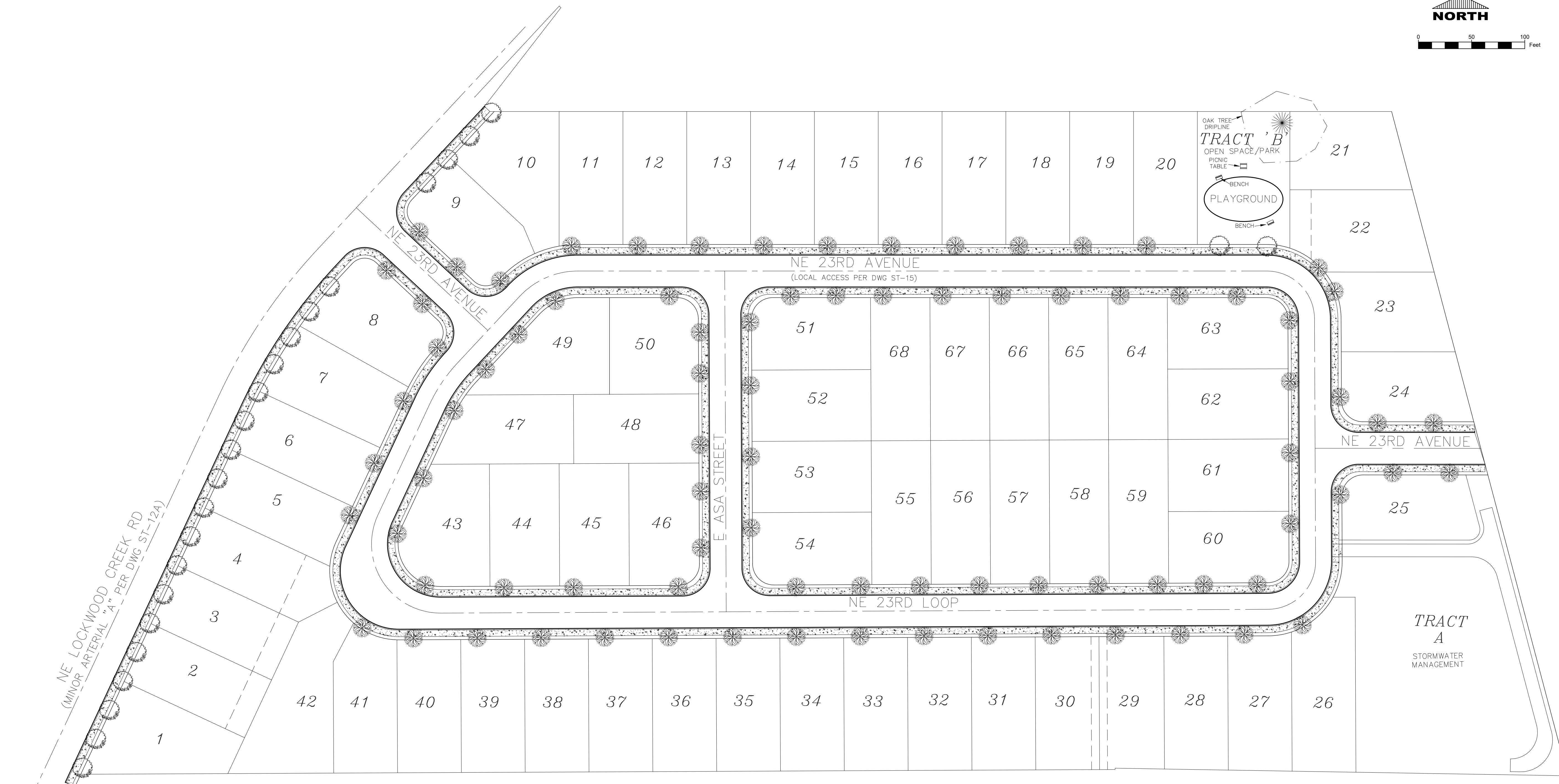

Asa's View
PRELIMINARY LANDSCAPE PLAN

PLANT SYMBOL	PLANT NAME	NUMBER OF PLANTS
	ACER BUERRGERANUM - TRIDENT MAPLE (SPREAD 20' HEIGHT 25') OR SIMILAR OTHER FROM LIST OF APPROVED STREET TREES. TO BE INSTALLED WITH CONSTRUCTION OF THE SUBDIVISION.	24 TREES
	ACER BUERRGERANUM - TRIDENT MAPLE (SPREAD 20' HEIGHT 25') OR SIMILAR OTHER FROM LIST OF APPROVED STREET TREES. TO BE INSTALLED WITH CONSTRUCTION OF INDIVIDUAL HOME, PLACEMENT MAY VARY.	85 TREES
	EXISTING 40" OREGON WHITE OAK TO BE RETAINED	1 TREE

- NOTES:
- ALL PLANTING MATERIAL AND LOCATION TO BE FINALIZED WITH THE FINAL LANDSCAPE INSTALLATION
 - ALL LANDSCAPING INSTALLED BY THE DEVELOPER (OPEN SPACES, TRAILS, ETC) SHALL BE AUTOMATICALLY IRRIGATED BY MEANS OF A PERMANENT UNDERGROUND SYSTEM TO INSURE PLANT SURVIVAL.
 - IRRIGATION SYSTEM SHALL BE "DESIGN BUILD" BY THE LANDSCAPE CONTRACTOR, INSTALLING ALL WORK NECESSARY FOR THE COMPLETE INSTALLATION OF THE IRRIGATION SYSTEM, INCLUDING ZONING, BACKFLOW DEVICES AND POWER NEEDED FOR THE SYSTEM AND MONUMENT SIGNS. CONTRACTOR SHALL BE REQUIRED TO OBTAIN APPROVAL OF AGENCY FOR THE IRRIGATION SYSTEM PRIOR TO CONSTRUCTION.
 - ALL IRRIGATION WILL BE INCLUDED WITH THE FINAL LANDSCAPE INSTALLATION
 - INTERIOR STREET TREE SPECIES AND PLACEMENT WILL BE DETERMINED WITH THE BUILDING PERMIT TO ACCOMMODATE FUTURE HOMEOWNER PREFERENCE AND CONFLICTS WITH DRIVEWAYS AND UTILITIES
 - SIGHT DISTANCE WILL BE MAINTAINED AT ALL INTERSECTIONS

NO.	DATE	REVISIONS

DRAWING SCALE:
AS SHOWN ON PLAN
DATE:
5/8/2022
SHEET NO.
11
INDEX NUMBER 11 OF 11

PRELIMINARY PLANS

Appendix D.
Geotechnical Report

**PRELIMINARY GEOTECHNICAL ENGINEERING STUDY
W/INFILTRATION**

**Proposed Lockwood Creek Subdivision
2313 NE Lockwood Creek Road
La Center, Clark County, WA 98629
(Parcel No.'s 209064000 and 209121000)**

Prepared for:

**Gravitate Capital, LLC
13563 NW Fuller Lane
Portland, OR 97229**

Prepared By:



**Seth A. Chandlee
President**



**Paul Williams, PE
Project Engineer**

**Project No. G0372200
{May 2022}**

**Soil and Water Technologies, Inc.
1101 Broadway, Suite 216 | Vancouver, Washington 98660
(360) 200-8693 / www.swt.ski**

TABLE OF CONTENTS

INTRODUCTION.....	1
General	1
Project Description.....	1
SITE CONDITIONS.....	1
Surface.....	1
Subsurface	2
Infiltration Testing.....	2
Groundwater.....	3
General Regional Geology	3
GEOLOGIC HAZARDS.....	4
Seismic Hazards	4
<i>Ground Motion Amplification</i>	4
<i>Liquefaction</i>	4
<i>Fault Rupture</i>	5
Seismic Design Criteria:.....	5
General	5
Foundations	6
Slab on Grade	6
Dewatering	7
Site Drainage	7
Pavement Areas.....	7
CONSTRUCTION RECOMMENDATIONS.....	8
Site Earthwork and Grading.....	8
Wet Weather Construction & Moisture Sensitive Soils:.....	9
Erosion Control	10
Expansive/Shrink Soil Capacity.....	10
Utility Support and Backfill	10
Temporary Excavations.....	11

GRAPHICS

Figure 1	Vicinity Map
Figure 2	Site Plan (Test Pit Locations)
Figure 3	Typical Footing and Drainage Detail
Figure 4	Utility Trench Backfill Detail
Appendix A	Field Exploration
Plate A1	Unified Soil Classification – Legend
Plates A2 to A4	Logs of Exploratory Test Pit Logs
Appendix B	Laboratory Testing
LPL 1	Atterberg Limits
Ei-1	Expansion Index

INTRODUCTION

General

This report presents the results of the geotechnical engineering study completed by Soil and Water Technologies, Inc. (SWT) for the proposed Lockwood Creek Subdivision located in Vancouver, Washington. The general location of the site is shown on the *Vicinity Map, Figure 1*. Our approximate exploratory test pits / infiltration locations are shown in relation to the site on the *Site Plan, Figure 2*.

The purpose of this study is to explore and evaluate subsurface conditions at the site and provide geotechnical recommendations for the proposed construction based on the conditions encountered. These recommendations include site specific geotechnical parameters for foundation support, earthwork grading, stormwater infiltration, site drainage, erosion control and a seismic hazard evaluation.

Project Description

Since a preliminary site plan was not provided at the time this report was written, this report should be considered preliminary and once available, undergo further grading plan review. However, based on our recent conversation and site investigation, we anticipate that the combined 18.57-acre properties, designated tax parcel No.'s 209064000 and 209121000, will be developed into a residential subdivision. Based on existing site grades, we anticipate minimal cuts/fills ranging from 1 to 2 feet in thickness across the site. The project will also include essential underground utilities (sanitary sewer, storm, domestic water) and onsite paved roadways.

Specific structural design loads were also not available, however, based on our experience with similar projects, we anticipate that wall loads will be approximately 700 to 1,500 pounds per lineal foot (plf). Slab-on-grade floor loads will most likely range from one hundred to one hundred and fifty pounds per square foot (100-150 psf).

If any of the above information is incorrect or changes, we should be consulted to review the recommendations contained in this report. In any case, it is recommended that Soil and Water Technologies perform a general review of the final design.

SITE CONDITIONS

Surface

As shown on our *Site Plan, figure 2*, the subject site is located to the southwest of the intersection of NE Lockwood Creek Road and NE 24th Avenue, on the south side of NE Lockwood Creek Road in La Center, Washington. The subject property is bordered to the west by the newly constructed La Center Highschool, to the south by a single-family residence on land, to the east by undeveloped vacant land, and north by NE Lockwood Creek Road.

The 2-parcel site is relatively level (0-5% slope), with a gentle south-facing slope the runs adjacent to Lockwood Creek Road (5-10%) at the north side of the site. The total elevation change across the properties is about 10 feet. According to Clark County Maps Online imagery layers, the two properties were historically used as agricultural farming with an existing residence and associated structures dating back to 1955. All structures were removed between 2016 and 2018 and the site consists predominantly of field grass with a gravel parking area at the northeast corner. A gravel roadway (NE 23rd Avenue) also runs north and south between the two parcels in the center of the site.

Subsurface

On March 25th, 2022, and April 4th, 2022, we evaluated the subsurface soil conditions by excavating a total of 1 infiltration test pit (I-1) and 4 exploratory test pits, designated TP-2 through TP-5 to the maximum explored depth of 8.0 feet below the existing ground surface (bgs). All exploration locations were selected by SWT to determine subsurface conditions across the site in regard to proposed development. The approximate locations are shown on the *Site Plan, Figure 2*.

All soil was classified in general accordance with the *Unified Soil Classification System (USCS)*. Soil samples obtained from the test pits were returned to our office for additional evaluation and laboratory testing. Descriptions of field and laboratory procedures are included in Appendices A and B, respectively.

The following is a generalized description of the subsurface units encountered. For a more detailed description of the conditions encountered, refer to test pit logs A2 through A4.

SURFACE MATERIALS: Surface materials encountered in the test pits consisted of approximately 4 - 6 inches of organic topsoil, wood chips and tree roots. A tilled zone resulting from agricultural farming is present in the upper approximate 1.5 feet.

SANDY LEAN CLAY Native sandy Lean Clay (CL) was encountered below the surface materials at each test pit to depths ranging from 0.5 to 7.0 feet bgs. Except for TP-3, which consists of silty Gravels (fill). The lean clay layer was also encountered below the sandy Fat Clay (CH) at test pits I-1 and TP-3 to depths ranging from 2.5/4.0 to 8.0 feet bgs. The sandy Lean Clay (CL) was brown, soft to stiff and in a moist condition. The moisture content of the 5 samples collected from this layer ranged from 30.8 to 36.4 percent with a fines content ranging from 58.3 to 86.7 percent. The upper ~ 1.5 feet of this layer predominantly consists of a tilled zone from agriculture farming. The expansion index of this layer is 13.

SANDY FAT CLAY Native sandy Fat Clay (CH) was encountered below the lean Clay (CL) layer at test pits I-1 and TP-3 to depths ranging from 1.0 to 2.5/4.0 feet bgs. The sandy Fat Clay (CH) was gray/brown, stiff to very stiff and in a moist condition. The moisture content of the 3 samples collected from this layer ranged from 25.7 to 34.2 percent with a fines content ranging from 79.6 to 88.1 percent. The Atterberg limits of this layer has a liquid limit of 56 and a plasticity index of 36.

Infiltration Testing

Infiltration testing was performed at test pit I-1 at depths of 2.0 and 3.5 feet bgs. The approximate location of the infiltration test pit is shown on the *Site Plan, Figure 2*. The purpose of performing these tests was to determine if site subgrade soils are suitable for infiltration of stormwater and provide stormwater treatment and control for all onsite impervious surfaces after construction. Infiltration testing methods were performed in general accordance with 2021 Clark County Stormwater Manual requirements for the Single-Ring Falling Head Infiltration Test. The test pit was excavated to the desired depths and a 6-inch diameter PVC pipe was embedded into the exposed soil ~ 6 inches in depth. Following a minimum 4-hour pre-saturation period, the pipe was filled with water and timed as the head dropped. The test results were averaged and recorded in inches per hour (iph).

All soil was classified following the *Unified Soil Classification System* (USCS) and the *AASHTO Soil Classification System (M145)*. The following table provides the field coefficient infiltration test results and associated laboratory testing:

Location	USCS Soil Type	Approx. Depth to Groundwater	WWHM	Depth (ft.)	% Passing #200 sieve	% Moisture content	Field Coefficient of Permeability
I-1	CH	Not encountered to 8.0 ft. bgs	SG-4	2.0	88.1	32.7	0.08 iph
I-1	CH	Not encountered to 8.0 ft. bgs	SG-4	3.5	87.1	34.2	0.05 iph

(USCS) Unified Soil Classification System / (CH) – Clay with sand (high plasticity)
 (WWHM) Western Washington Hydrology Model / Soil Group 4 (poorly drained soils)

The coefficients of permeability presented were calculated using Darcy’s law in accordance with the 2021 CCSWM, but do not include base correction factors or system design correction factors as required by the guidelines. Additionally, it is recommended that the designer also include additional correction factors to account for the level of maintenance, type of system, vegetation, siltation, etc.

Based on the subsurface conditions encountered, the slow rate of infiltration and our laboratory test results, it is our opinion that the low permeable native sandy fat Clay (CH) encountered in test pit I-1, and across the site, *is not suitable* for the infiltration of stormwater and will require alternative management.

Groundwater

Due to the wet time of year and above-average rainfall, light to medium groundwater seepage was encountered in test pit TP-2, TP-4, and TP-5 at depths ranging from 2.0 to 5.0 feet bgs. Based on our review of Clark County Maps Online and the Department of Ecology well log database, static groundwater exceeds 30 feet in depth. However, the groundwater monitoring wells (piezometer) installed by Columbia West Engineering at the adjacent school property indicates groundwater depths of 3 feet bgs. during the months of April, 2018.

It is important to note that groundwater conditions are not static; fluctuations may be expected in the level and seepage of flow depending on the season, amount of rainfall, surface water runoff, and other factors. Generally, the groundwater level is higher and seepage rate is greater in the wetter winter months (typically October through May).

General Regional Geology

General information about geologic conditions and soil in the vicinity of the site was obtained by reviewing the USGS Geologic Map of Washington-Southwest Quadrant, WA. State Department of Natural Resources, (Geologic Map GM-34, 1987) and the Geologic Map of the Vancouver Quadrangle, Washington & Oregon, (DLNR), Open File Report 87-10 and the USDA web soil survey.

In the Late Pleistocene (17 -13 kya), a series of floods caused by the failure of the ice dam at Glacial Lake Missoula in western Montana caused the deposition of suspended sediments after the floodwaters

became hydraulically dammed north of the confluence of the Columbia and Lewis Rivers. Fine-grained sediments were deposited when the flood waters slowed down and deposited a series of distinct layers described as unconsolidated silty Sand, Silt, and Clay.

The native material encountered in our exploratory test pits consists predominantly fine-grained Clay (CL & CH) with sand consistent with cataclysmic-flood deposits, which represent weathered Late Pleistocene fine-grained sedimentary flood deposits attributed to Gee silt loam (GeB) and Odne silt loam (OdB) soil series. Both soil series consist predominately of fine-grained clays and silts with low to very low permeability and are moisture sensitive.

GEOLOGIC HAZARDS

The following provides a geologic hazard review for the subject site. The purpose of this investigation was to determine if geologic hazards are present on the site, and if so, to provide recommendations to mitigate their impacts on development. The geologic hazard review is based on our site reconnaissance and subsurface explorations, as well as a review of publicly available published literature and maps.

Seismic Hazards

The following seismic hazards have been considered as part of our geologic hazards review for the project site. Seismic hazards pertain to areas that are subject to risk of earthquake-induced damage. These hazards include ground shaking/motion amplification, soil liquefaction, geologic fault rupture, and landslides.

Ground Motion Amplification

According to the “Site Class Map layer of Clark County MapsOnline, the proposed site is designated as a seismic Site Class “C”. However, based on our subsurface explorations and laboratory test results, it is our opinion that a Site Class “D” is appropriate for use at the site. This designation indicates that some amplification of seismic activity may occur during a seismic event based on the subsurface soil conditions encountered.

Liquefaction

Structures are subject to damage from earthquakes due to direct and indirect action. Shaking represents direct action. Indirect action is represented by foundation failures and is typified by liquefaction. Liquefaction occurs when soil loses all shear strength for short periods of time during an earthquake. Ground shaking of sufficient duration then results in the loss of grain-to-grain contact as well as a rapid increase in pore water pressure. This causes the soil to assume the physical properties of a fluid.

To have potential for liquefaction a soil must be loose, cohesion-less (generally sands and silts), below the groundwater table, and must be subjected to sufficient magnitude and duration of ground shaking.

According to the “Liquefaction Susceptibility” layer of Clark County MapsOnline, the site is mapped as having a “very low” liquefaction susceptibility. Due to the medium stiff to stiff and predominately fine-grained soils encountered in our test pits, and the absence of near surface groundwater, it is our professional opinion that soil liquefaction and induced differential settlement will not occur at the subject site during a moderate to strong seismic event and that a “very low” susceptibility is adequate for the site.

It should be noted that directly south of the site, at a distance of approximately 0.35 mile, an area of moderate to high potential for liquefaction is indicated by Clark County MapsOnline. Additional testing would need to be performed to determine the liquefaction potential of the onsite soils and is beyond our scope of work for this report.

Fault Rupture

According to USGS Earthquake Hazards Program, there are a total of three major fault zones in the vicinity of the site that have the potential to cause or induce soil liquefaction and/or settlement. These faults are the Portland Hills Fault, Lacamas Lake-Sandy River Fault, and the Cascadia Subduction Zone. However, there are no historically active faults located in close proximity to the site. Due to the stiff soil conditions encountered in our test pits and distance from the mapped fault, a fault rupture is not considered a hazard at the site.

Seismic Design Criteria:

According to Clark County MapsOnline, supportive foundation soils encountered at the site are classified as a type “C” soil. However, based on our test pit explorations and laboratory testing, a type “D” soil is more appropriate for the site. For more detail regarding soil conditions refer to the soil logs in Appendix A of this report.

The seismic design criteria for this project found herein is based on the International Building Code (IBC) 2018 and the USGS website. A summary of IBC seismic design criterion is below.

Table 1. 2018 IBC Seismic Design Parameters		
Location (45.8587037, -122.6470354)	Short Period	1-Second
Maximum Credible Earthquake Spectral Acceleration	$S_s = 0.796 \text{ g}$	$S_1 = 0.374 \text{ g}$
Site Class	D	
Site Coefficient	$F_a = 1.181$	$F_v = 1.926$
Adjusted Spectral Acceleration	$S_{MS} = 0.941 \text{ g}$	$S_{M1} = 0.72$
Design Spectral Response Acceleration Parameters	$S_{DS} = 0.627 \text{ g}$	$S_{D1} = 0.48$

g – acceleration due to gravity

Due to the Site Class “D” designation and the long period MCES (S1) value exceeding 0.2 g, the structural engineer must apply the site-specific ground motion increases outlined in Section 11.4.8 of ASCE 7-16, including an increased of 50 percent to the seismic base shear coefficient, C_s . As an alternative to applying these conservative increases to the ground motions, a site-specific ground motion hazard analysis may be performed, however such an analysis was not included in the scope of this study.

GEOTECHNICAL DESIGN RECOMMENDATIONS

General

Based on the results of our study, it is our opinion the proposed residential development can be constructed as planned, provided the geotechnical recommendations contained in this report are incorporated into the final design. The following sections present detailed recommendations and parameters pertaining to the geotechnical engineering design for this project.

Foundations

Based on the encountered subsurface soil conditions, preliminary building design criteria, and assuming compliance with the preceding *Site Earthwork and Grading* section, the proposed residential building foundations should be supported on 12 inches of compacted crushed rock above a properly prepared native subgrade or compacted structural fill. Due to the high plasticity and heterogeneous condition of soil, it is recommended that the foundations bear on crushed aggregate. See *Site Earthwork and Grading* sections for soil preparation prior to form installation.

Individual spread footings or continuous wall footings providing support for the proposed buildings may be designed for a maximum allowable bearing value of 1,500 pounds per square foot (psf). Footings for one level structures should be at least 12 inches in width. Footings for two level structures should be at least 15 inches in width. Footings for three level structures should be at least 18 inches in width. All footings should extend to a depth of at least twelve (12) inches below the lowest adjacent finished sub grade.

These basic allowable bearing values are for dead plus live loads and may be increased one-third for combined dead, live, wind, and seismic forces. Lateral loads can be resisted by friction between the foundation and the supporting sub grade or by passive earth pressure acting on the buried portions of the foundation. For the latter, the foundations must be poured “neat” against the existing soil or back filled with a compacted fill meeting the requirements of structural fill.

- Passive Pressure = 305 pcf (equivalent fluid weight)
- Coefficient of Friction = 0.28

It is estimated that total and differential footing settlements for the relatively light residential building will be approximately one and one-half inches, respectively. It is recommended that an SWT representative be contacted to reevaluate removal limits during building construction and observe the condition of footing soils prior to the installation of forms/rebar.

Slab on Grade

If concrete floor slabs are desired, then any disturbed soils must be re-compacted prior to pouring concrete. Satisfactory subgrade support for lightly loaded building floor slabs can be obtained on the undisturbed native soil or on engineered structural fill. A subgrade modulus of 125 pounds per cubic inch (pcf) may be used to design floor slabs. If desired, it is recommended that the slab subgrade be evaluated by a geotechnical engineer to verify bearing conditions.

A minimum 6-inch-thick layer of free draining fill should be placed and compacted over the prepared subgrade to assist as a capillary break and blanket drain. It is also suggested that nominal reinforcement such as “6x6-10/10” welded wire mesh be employed, near midpoint, in new concrete slabs. In areas where slab moisture is undesirable, a vapor barrier such as a 6-mil plastic membrane should be placed beneath the slab.

Exterior concrete slabs that are subject to vehicle traffic loads should be at least 6 inches in thickness. It is also suggested that nominal reinforcement such as “6x6-10/10” welded wire mesh be installed, near midpoint, in new exterior concrete slabs and paving. Fiber mesh concrete may be used in lieu of welded wire mesh.

Dewatering

Our subsurface investigation indicates that groundwater seepage was encountered at depths ranging from 2.0 to 5.0 feet below the existing ground surface and will fluctuate in response to precipitation. Excavations that extend below the groundwater level may result in caving or heaving. This may require pumping to temporarily reduce the amount of groundwater present to allow for the installation of underground utilities or the placement and compaction of structural fills. The contractor should consider the use of a network of ditches and sumps, into which water can flow to be pumped out of the excavation.

The depth and dewatering time will need to be determined at the time of construction and adjusted depending on site conditions. If water is encountered, the contractor should be prepared and is responsible for appropriate dewatering and discharge methods. Unprotected working should not be allowed near temporary un-shored excavations until groundwater levels have been stabilized and shoring, such as lagging, has been installed.

Site Drainage

During earthwork construction, a plan for the collection and conveyance of surface water to an appropriate management facility should be in place to control runoff. Final site grading should direct surface water off the site to prevent standing/ponding water and away from proposed buildings, structures and/or roadway. Water should also not be allowed to stand in any area where buildings or foundations are to be constructed. Loose surfaces should be sealed at the end of each workday by compacting the surface to reduce the potential of moisture infiltrating into and degrading the exposed soil.

The ground should be sloped at a gradient of a minimum of 2 percent for a distance of at least 10 feet away from the buildings. We suggest that a foundation footing drain be installed around the perimeter of all buildings. The drain should consist of a 4-inch diameter perforated pipe and installed in an envelope of clean drain rock or pea gravel wrapped with free draining filter fabric. The drain should be a minimum of one-foot-wide and one-foot-deep with sufficient gradient to initiate flow. The drain should be routed to a suitable discharge area. Details for the footing drain have been included as *Figure 3, Typical Footing Subdrain Detail*.

Under no circumstances should the roof down spouts be connected to the perimeter building drain. We suggest that clean outs be installed at several accessible locations to allow for the periodic maintenance of the drain system.

Pavement Areas

Hot mix asphalt (HMA) and crushed rock base (CRB) materials should conform to WSDOT specifications. All pavement area subgrades should consist of compacted native soil or engineered structural fill and be compacted to at least 95 percent of the modified proctor, determined by ASTM D1557. The subgrade conditions should be assessed and tested by SWT prior to the placement of the roadway aggregate section. This includes nuclear gauge density testing and proof-rolling observations with a fully loaded haul truck or equivalent. Any soft areas identified during the proof rolling process should be removed to a competent subgrade and replaced with compacted crushed aggregate.

Based on our laboratory testing, visual observations and local knowledge of soil types in the area, the subgrade soils shall be considered an AASHTO soil type A-4 to A-7. Based on the anticipated traffic

loading, we recommend that a minimum of 4 inches of AC underlain by 12 inches of compacted CRB be applied at all public right-of-way and road improvement areas.

Pavements should be sloped to provide rapid drainage of surface water. Water allowed to pond on or adjacent to the pavements have the potential to saturate the subgrade and contribute to premature pavement deterioration. In addition, the pavement subgrade should be graded to provide positive drainage within the granular base section.

The subgrade and the pavement surface should have a minimum $\frac{1}{4}$ inch per foot slope to promote drainage. Appropriate sub-drainage or connection to a suitable daylight outlet should be provided to remove water from the base layer.

CONSTRUCTION RECOMMENDATIONS

Site Earthwork and Grading

Clearing and Grubbing:

Prior to grading, the project area should be cleared of all rubble, trash, debris, etc. Any buried organic debris, undocumented fill or other unsuitable material encountered (soft soils) during subsequent excavation and grading work should also be removed. Excavations for removal of any existing footings, slabs, walls, utility lines, tanks, and any other subterranean structures should be processed and backfilled in the following manner:

- Clear the excavation bottom and side cuts of all loose and/or disturbed material.
- Once the organic topsoil has been adequately removed (~ 4 to 6 inches), the upper 1.5 feet of native soil (tilled zone) shall be scarified to a competent subgrade (stiff Clay) and dried to within 2 percent *above* its optimal moisture content and re-compacted in 8–10-inch lifts. Density testing shall be performed prior to placement of additional fill.
- Structural fill shall be placed in loose lifts not exceeding 8 inches in thickness and compacted with adequate equipment (eg. segmented pad roller) to at least 95% of the ASTM D-1557 laboratory test standard.
- Prior to placing backfill, the excavation bottom should be dried or moisture conditioned to within 2 percent of the optimum moisture content and compacted to at least 95 percent of the ASTM D-1557 laboratory test standard.
- Backfill should be placed, moisture conditioned (i.e., watered and/or aerated as required and thoroughly mixed to a uniform, near optimum moisture content), and compacted by mechanical means in approximate 6-inch lifts. The degree of compaction obtained should be at least 95 percent of the ASTM D-1557 laboratory test standard, as applicable.
- Any large trees should be removed from any fill areas. Any remaining root balls, possibly reaching 3+ feet in depth, should be adequately removed and backfilled with approved structural fill. We recommend an SWT representative observe the removal and provide monitoring and density testing of compacted structural fill/backfill at all removal areas.

It is also critical that any surficial subgrade materials disturbed during initial demolition and clearing work be removed and/or re-compacted during subsequent site preparation earthwork operations.

It is important to note that all soft undocumented fill, if present, is to be over-excavated to a competent subgrade and replaced with suitable structural fill. Supporting the proposed buildings on homogeneous material will significantly decrease the potential for differential settlement across the foundation area. In order to create uniform subgrade support conditions, in the vicinity of undocumented fill areas if encountered, the following earthwork operations are recommended:

- Over-excavate existing soils to a competent native subgrade below the bottom of the proposed foundations. The excavations should extend at least one-half width laterally beyond the foundation footprint, or as constrained by existing structures. In addition, native soil removal shall extend to a minimum depth so that a maximum 2:1 ratio of differential structural fill thickness is maintained below all building spread foundation systems.
- The fill soils placed shall consist of clean soils with an expansion index (EI) less than twenty (20), and be free of organic material, debris, and rocks greater than 3 inches in maximum diameter. Based on the field observations and laboratory testing, the existing native soil consisting of Silt (ML) with sand and the underlying Clay (CH) with sand is suitable for use as structural fill so long as the material is within two percent (2%) of its optimum moisture content prior to compaction.
- The backfill shall consist of minimum ninety-five percent (95%) compacted fills (Note: ASTM D1557). In addition to the relative compaction requirements, all fills shall be compacted to a firm non-yielding condition.
- Import soils should be sampled, tested, and approved by SWT prior to arrival on site. Imported soils shall consist of clean soils (EI of 20 or less) free from vegetation, debris, or rocks larger than three inches in maximum dimension.

Subgrade Verification and Proof Rolling

After clearing and grading the site, it is possible that some localized areas of soft, wet or unstable subgrade may still exist. Before placement of any roadway base rock, the subgrade should be scarified 8 inches in depth and compacted with suitable compaction equipment. Yielding areas that are identified should be excavated to medium dense/stiff material and replaced with compacted two inch-minus clean crushed rock. All building and pavement areas should be compacted to a dense non-yielding condition with suitable compaction equipment. This phase of earthwork compaction shall be performed prior to the placement of any structural fill, at the bottom of all foundation excavations and along the roadway subgrade, before the placement of base rock.

Wet Weather Construction & Moisture Sensitive Soils:

Field observations and laboratory testing indicates that the upper subsurface soil layer at the site consists of native lean Clay (CL) with sand and is a fine-grained moisture sensitive material. As such, in an exposed condition, moisture sensitive soil can become disturbed during normal construction activity, especially when in a wet or saturated condition. Once disturbed, in a wet condition, these soils will be unsuitable for support of foundations, floor slabs and roadways.

Therefore, where soil is exposed and will support new construction, care must be taken not to disturb their condition. Equipment traffic should be minimized across exposed soils to reduce the amount of disturbance and creation of excess soft wet soil. If disturbed soil conditions develop, the affected soil must be removed and replaced with structural fill. The depth of removal will be dependent on the depth of disturbance developed during construction. Covering the excavated area with plastic and refraining

from excavation activities during rainfall will minimize the disturbance and decrease the potential degradation of supportive soils.

If construction proceeds during wet weather condition, roadway base sections may require to be increased or stabilized with 2–6-inch gabion/ballast with no fines. Soil cement treatment may also be required to provide a stable roadway or building subgrades. If this is considered, SWT should be contacted to provide the appropriate recommendations based on the soil moisture conditions and collect the necessary samples to perform laboratory testing to determine the optimum soil:cement ratio.

Erosion Control

If construction extends into the winter “rainy” season, earthwork activities are feasible if proper erosion control measures are implemented to minimize degradation to both native and structural fill soils. Due to the relatively flat topography of the site, erosion hazards are likely to be low. All surface stormwater, if encountered, should be captured and directed away from structural areas by means of site-specific erosion control measures including conveyance trenches, straw wattles, sediment fences, temporary sediment ponds etc.

Expansive/Shrink Soil Capacity

Laboratory testing of the native lean Clay (CL) with sand at depths ranging from 1.0/1.5 feet to the maximum explored depth of 8.0 feet bgs, indicates this soil has an Expansion Index (EI) of 13. An EI of 13 suggests a very low to low potential for soil shrinking and swelling. However, the importance for adequate soil conditioning during the placement and compaction of structural fill is essential. Soils with a high plasticity index such as the fat Clay (CH), which was also encountered across the site, should be placed and compacted with a moisture content at ~ 2 percent above its optimum moisture to avoid the potential for shrinking or swelling over time.

It is recommended that earthwork grading of expansive soils be closely monitored by an experienced geotechnical engineer or their representatives. To help avoid soil swelling, regulating soil moisture content and mixing of expansive clays with less plastic soils should be properly conditioned during fill placement and compaction.

Utility Support and Backfill

Based on the conditions encountered, the soil to be exposed by utility trenches should provide adequate support for utilities. Utility trench backfill is a concern in reducing the potential for settlement along utility alignments, particularly in pavement areas. It is also important that each section of utility line be adequately supported in the bedding material. The backfill material should be hand tamped to ensure support is provided around the pipe haunches.

Fill should be carefully placed and hand tamped to about twelve inches above the crown of the pipe before any compaction equipment is used. The remainder of the trench backfill should be placed in lifts having a loose thickness of eight inches. Utility trench backfill should consist of *WSDOT 9-03.19 Bank Run Gravel for Trench Backfill* or *WSDOT 9-03.14(2) Select Borrow* with a maximum particle size of 2-1/2-inches.

A typical trench backfill section and compaction requirements for load supporting and non-load supporting areas is presented on *Figure 4, Utility Trench Backfill Detail*.

Temporary Excavations

The following information is provided solely as a service to our client. Under no circumstances should this information be interpreted to mean that SWT is assuming responsibility for construction site safety or the contractor's activities; such responsibility is not being implied and should not be inferred. In no case should excavation slopes be greater than the limits specified in local, state and federal safety regulations. The contractor should be aware that excavation and shoring should conform to the requirements specified in the applicable local, state, and federal safety regulations, such as OSHA Health and Safety Standards for Excavations, 29 CFR Part 1926, or successor regulations. We understand that such regulations are being strictly enforced, and if not followed, the contractor may be liable for substantial penalties.

Based on the information obtained from our field exploration and laboratory testing, the onsite soils expected to be encountered in excavations will most likely consist of native lean Clay and fat Clay. These soils encountered are classified predominately as a type "A" soil. Therefore, temporary excavations and cuts greater than four feet in height, should be sloped at an inclination no steeper than 3/4H:1V (horizontal to vertical).

If slopes of this inclination, or flatter, cannot be constructed, or if excavations greater than four feet in depth are required, temporary shoring may be necessary. This shoring would help protect against slope or excavation collapse and would provide protection to workmen in the excavation. If temporary shoring is required, we will be available to provide shoring design criteria, if requested.

LIMITATIONS

Our recommendations and conclusions are based on the site materials observed, selective laboratory testing, engineering analyses and other design information provided to Soil and Water Technologies as well as our experience and engineering judgment. The conclusions and recommendations are professional opinions derived in a manner consistent with that level of care and skill ordinarily exercised by other members of the profession currently practicing under similar conditions in this area. No warranty is expressed or implied.

The recommendations submitted in this report are based upon the data obtained from our test pits. Soil and groundwater conditions between the test pits may vary from those encountered. The nature and extent of variations may not become evident until construction. If variations do appear, Soil and Water Technologies should be requested to reevaluate the recommendations contained in this report and to modify or verify them in writing prior to proceeding with the proposed construction.

Temporary construction excavation and site safety are the sole responsibility of the construction contractor who also is solely responsible for the means, methods, and sequencing of construction operations. We are providing the following information only as a service to our client for planning purposes by their design team. Under no circumstances should the information provided herein be interpreted to mean that SWT is assuming responsibility for construction site safety or the contractor's activities; such responsibility is not being implied and should not be inferred.

VICINITY MAP



Soil and Water Technologies, Inc
 1101 Broadway | Suite 216
 Vancouver, WA 98660
 PH: (360) 200-8693
www.swt.ski



CLIENT: Gravitate Capital, LLC
PROJECT: Lockwood Creek Subdivision
 2313 NE Lockwood Creek Road
 La Center, WA 98629

DRAWN: RN
DATE: 4/5/2022
FIGURE: 1
PRO. #: G0372200

SITE MAP

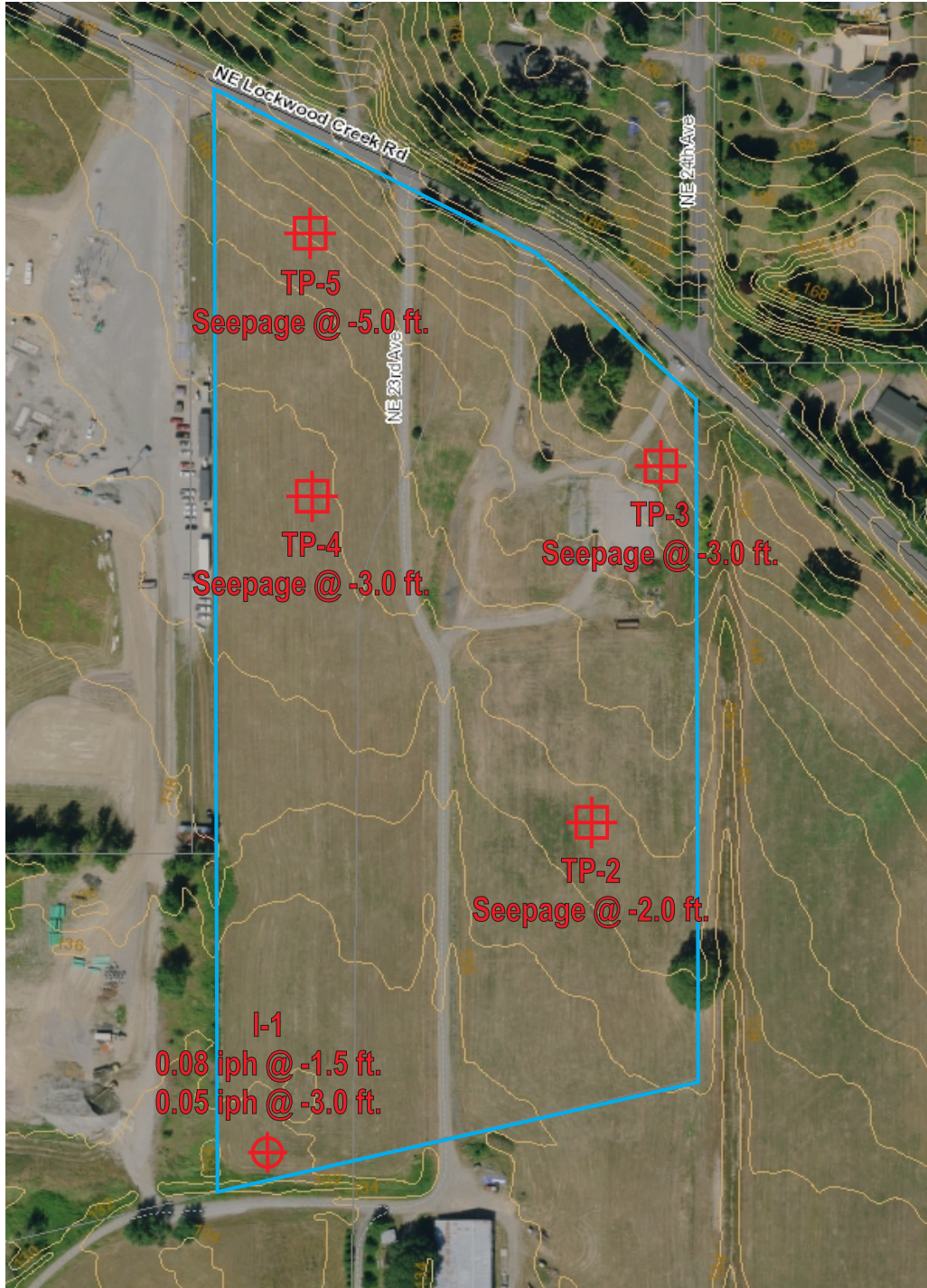

Legend

- I-1** Approximate Infiltration Test Pit Location
- TP-2** Approximate Test Pit Location

iph - Inches Per Hour

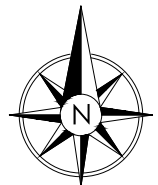

Soil and Water Technologies, Inc
 1101 Broadway | Suite 216
 Vancouver, WA 98660
 PH: (360) 200-8693
 www.swt.ski



<i>CLIENT:</i> Gravitate Capital, LLC	<i>DRAWN:</i> RN
<i>PROJECT:</i> Lockwood Creek Subdivision 2313 NE Lockwood Creek Road La Center, WA 98629	<i>DATE:</i> 3/8/2022
	<i>FIGURE:</i> 2
	<i>PRO. #:</i> G0262200

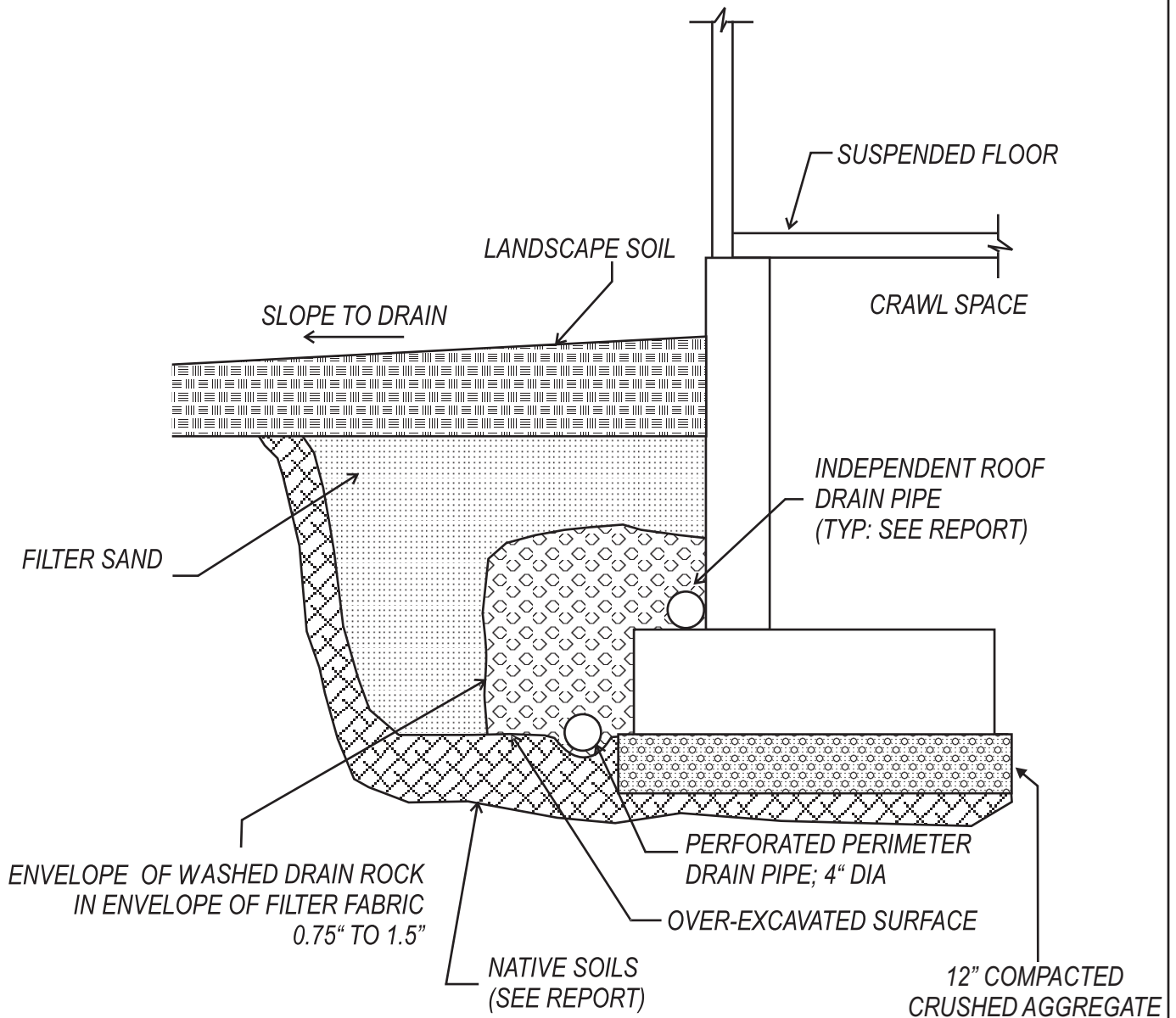

NOTES:

1. FILTER SAND - FINE AGGREGATE FOR PORTLAND CEMENT; SECTION 9=03.1(2)
2. PERFORATED OR SLOTTED RIGID PVC PIPE WITH A POSITIVE DRAINAGE GRADIENT
3. FOOTINGS INSTALLED ABOVE 12" COMPACTED CRUSHED AGGREGATE; 95% OF MODIFIED PROCTOR (ASTM D1557)

TYPICAL SUSPENDED FOOTING DETAIL

Not to Scale

Soil and Water Technologies, Inc
 PO Box 59
 Vancouver, WA 98666
 PH: (360) 200-8693
 www.swt.ski



CLIENT:	Gravitate Capital, LLC	DRAWN:	RN
PROJECT:	Lockwood Creek Subdivision 2313 NE Lockwood Creek Road La Center, WA 98629	DATE:	4/10/2022
		FIGURE:	3
		PRO. #:	G0372200

APPENDIX A
(FIELD EXPLORATION)

FIELD EXPLORATION

Our field exploration was performed on March 25th and April 4th, 2022. Subsurface conditions at the site were explored by excavating a total of 1 infiltration test pit (I-1) and 4 test pits TP-2 – TP-5 with an excavator and hand auger to the maximum explored depth of 7.0 feet below the existing ground surface.

The approximate test pit locations were determined by the Soil and Water Technologies, Inc. by pacing from existing site features. These approximate locations are shown on the *Site Plan, Figure 2*.

The field exploration was monitored by Soil and Water Technologies, who classified the soil encountered and maintained a log of each test pit, obtained representative samples, and observed pertinent site features. Representative soil samples were placed in sealed plastic bags and returned to the laboratory for further examination and testing.

All samples were visually classified in accordance with the Unified Soil Classification System (USCS), which is presented on *Plate A1*. Logs of the test pits are presented in *Appendix A*. The final logs represent our interpretations of the field logs and the results of the laboratory tests on field samples. The stratification lines on the logs represent the approximate boundaries between soil types. In fact, the transitions may be more gradual.

UNIFIED SOIL CLASSIFICATION SYSTEM LEGEND

MAJOR DIVISIONS			GRAPH SYMBOL	LETTER SYMBOL	TYPICAL DESCRIPTION	
Coarse Grained Soils	Gravel and Gravelly Soils	Clean Gravels (little or no fines)		GW / gw	Well-Graded Gravels, Gravel-Sand Mixtures Little or no Fines	
		Gravels with Fines (appreciable amount of fines)		GP / gp	Poorly-Graded Gravels, Gravel-Sand Mixtures, Little or no Fines	
	More Than 50% Coarse Fraction Retained on No 4 Sieve	Gravels with Fines (appreciable amount of fines)		GM / gm	Silty Gravels, Gravel-Sand-Silt Mixtures	
				GC / gc	Clayey Gravels, Gravel-Sand-Clay Mixtures	
More Than 50% Material Larger Than No 200 Sieve Size	Sand and Sandy Soils	Clean Sand (little or no fines)		SW / sw	Well-graded Sands, Gravelly Sands Little or no Fines	
		More Than 50% Coarse Fraction Retained on No 4 Sieve		SP / sp	Poorly-Graded Sands, Gravelly Sands Little or no Fines	
	Sands with Fines (appreciable amount of fines)	Sands with Fines (appreciable amount of fines)		SM / sm	Silty Sands, Sand-Silt Mixtures	
				SC / sc	Clayey Sands, Sand-Clay Mixtures	
Fine Grained Soils	Sils and Clays	Liquid Limit Less than 50		ML / ml	Inorganic Silts and Very Fine Sands, Rock Flour, Silty-Clayey Fine Sands; Clayey Silts w/ slight Plasticity	
				CL / cl	Inorganic Clays of Low to Medium Plasticity, Gravelly Clays, Sandy Clays, Silty Clays, Lean	
				OL / ol	Organic Silts and Organic Silty Clays of Low Plasticity	
	More Than 50% Material Smaller Than No 200 Sieve Size	Sils and Clays	Liquid Limit Greater than 50		MH / mh	Inorganic Silts, Micaceous or Diatomaceous Fine Sand or Silty Soils
					CH / ch	Inorganic Clays of High Plasticity, Fat Clays
					OH / oh	Organic Clays of Medium to High Plasticity, Organic Silts
Highly Organic Soils				PT / pt	Peat, Humus, Swamp Soils with High Organic Contents	

Topsoil		Humus and Duff Layer
Fill		Highly Variable Constituents

SAMPLING DESCRIPTIONS			
● Grab Sample	SPT Drive Sampler (ASTM D1586)	Shelby Tube Push Sampler (ASTM D1587)	Dames and Moore Drive Sampler (ASTM D3550)

Soil and Water Technologies, Inc 1101 Broadway, Suite 216 Vancouver, WA 98660 PH: (360) 200-8693 www.swt.ski		CLIENT: Gravitate Capital, LLC	DRAWN: RN
		PROJECT: Lockwood Creek Subdivision	DATE: 4/10/2022
		2313 NE Lockwood Creek Road	PLATE: A1
		La Center, WA 98629	PRO. #: G0372200

LOG OF TEST PIT

I-1

ELEVATION: **133 +/- feet**

EXPLORATORY EQUIPMENT: **Track-Hoe**

DATE: **3/25/2022**

DEPTH IN FEET	SAMPLES	SOILS CLASSIFICATION	LITHOLOGY (USGS)	MOISTURE CONTENT % OF DRY WEIGHT	PERCENT PASS NUMBER 200	NOTES
1		<i>brown, soft, moist sandy lean Clay (CL)</i>				4" organic topsoil
2	●	<i>brown/gray, stiff to very stiff sandy Fat Clay (CH)</i> <i>moist</i>		32.7	88.1	Infiltration Testing - 0.08 iph @ 2.0 ft. bgs
3	●			34.2	87.1	Infiltration Testing - 0.05 iph @ 3.5 ft. bgs
4						
5		<i>brown, stiff sandy Lean Clay (CL)</i> <i>moist</i>				{AASHTO A-7-6(34)} {mottling}
6						
7						
8				32.6	84.3	

Bottom of test pit at 8.0 feet below existing ground surface (bgs).
No groundwater encountered.

Soil and Water Technologies, Inc 1101 Broadway Suite 216 Vancouver, WA 98660 PH: (360) 200-8693 www.swt.ski		CLIENT: Gravitare Capital, LLC	DRAWN: RN
		PROJECT: Lockwood Creek Subdivision	DATE: 4/6/2022
		2313 NE Lockwood Creek Road	PLATE: A2
		La Center, WA 98629	PRO. #: G0372200

LOG OF TEST PIT

TP-2

ELEVATION: **140 +/- feet**

EXPLORATORY EQUIPMENT: **Track-Hoe**

DATE: **3/25/2022**

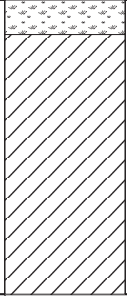
DEPTH IN FEET	SAMPLES	SOILS CLASSIFICATION	LITHOLOGY (USGS)	MOISTURE CONTENT % OF DRY WEIGHT	PERCENT PASS NUMBER 200	NOTES
1	●			27.9	83.6	6" organic topsoil {till zone - soft from -0.5' to -1.0'}
2	● ▼	gray/brown, soft to stiff sandy <u>Lean Clay (CL)</u> moist		30.8	86.7	{perched seepage @ 2.0 ft. bgs} {EI - 13} {1.5 tsf on penetrometer}
3						
4						
5						

Bottom of test pit at 5.0 feet below existing ground surface (bgs).
Perched seepage encountered .

Soil and Water Technologies, Inc 1101 Broadway Suite 216 Vancouver, WA 98660 PH: (360) 200-8693 www.swt.ski		CLIENT: Gravitare Capital, LLC	DRAWN: RN
		PROJECT: Lockwood Creek Subdivision	DATE: 4/8/2022
		2313 NE Lockwood Creek Road	PLATE: A3
		La Center, WA 98629	PRO. #: G0372200

LOG OF TEST PIT

TP-3

ELEVATION: **150 +/- feet**

EXPLORATORY EQUIPMENT: **Track-Hoe**

DATE: **3/25/2022**

DEPTH IN FEET	SAMPLES	SOILS CLASSIFICATION	LITHOLOGY (USGS)	MOISTURE CONTENT % OF DRY WEIGHT	PERCENT PASS NUMBER 200	NOTES
1	●	soft, silty Gravels	fill		-	
2	●	gray, medium stiff, moist sandy Fat Clay (CH)	native	25.7	79.6	
3		gray/brown, stiff sandy Lean Clay (CL)				{mottling}
4	●	moist		35.8	75.5	

Bottom of test pit at 4.5 feet below existing ground surface (bgs).
No groundwater encountered.

Soil and Water Technologies, Inc 1101 Broadway Suite 216 Vancouver, WA 98660 PH: (360) 200-8693 www.swt.ski		CLIENT: Gravitare Capital, LLC	DRAWN: RN
		PROJECT: Lockwood Creek Subdivision	DATE: 4/8/2022
		2313 NE Lockwood Creek Road	PLATE: A4
		La Center, WA 98629	PRO. #: G0372200

LOG OF TEST PIT

TP-4

ELEVATION: **142 +/- feet**

EXPLORATORY EQUIPMENT: **Track-Hoe**

DATE: **4/4/2022**

DEPTH IN FEET	SAMPLES	SOILS CLASSIFICATION	LITHOLOGY (USGS)	MOISTURE CONTENT % OF DRY WEIGHT	PERCENT PASS NUMBER 200	NOTES
1		gray/ brown, medium stiff to stiff sandy Lean Clay (CL) moist	native	-	-	{till zone - med. stiff from -0.5' to -1.5'}
2				36.4	58.3	{Dry PCF - 81.0}
3	● ▼					{perched seepage @ 3.0 ft. bgs}
4						

Bottom of test pit at 4.0 feet below existing ground surface (bgs).
No groundwater encountered.

Soil and Water Technologies, Inc 1101 Broadway Suite 216 Vancouver, WA 98660 PH: (360) 200-8693 www.swt.ski		CLIENT: Gravitare Capital, LLC	DRAWN: RN
		PROJECT: Lockwood Creek Subdivision	DATE: 4/8/2022
		2313 NE Lockwood Creek Road	PLATE: A5
		La Center, WA 98629	PRO. #: G0372200

LOG OF TEST PIT

TP-5

ELEVATION: **146 +/- feet**

EXPLORATORY EQUIPMENT: **Track-Hoe**

DATE: **4/4/2022**

DEPTH IN FEET	SAMPLES	SOILS CLASSIFICATION	LITHOLOGY (USGS)	MOISTURE CONTENT % OF DRY WEIGHT	PERCENT PASS NUMBER 200	NOTES
1						4" organic topsoil
2						{till zone - soft from -0.5' to -1.5'}
3	●	gray/brown, soft to stiff sandy Lean Clay (CL) moist		34.5	34.5	
4						
5	▼					{perched seepage @ 5.0 ft. bgs}
6						
7			native			

Bottom of test pit at 7.0 feet below existing ground surface (bgs).
No groundwater encountered.

Soil and Water Technologies, Inc
1101 Broadway | Suite 216
Vancouver, WA | 98660
PH: (360) 200-8693
www.swt.ski



CLIENT: Gravitare Capital, LLC
PROJECT: Lockwood Creek Subdivision
2313 NE Lockwood Creek Road
La Center, WA 98629

DRAWN: RN
DATE: 4/8/2022
PLATE: A6
PRO. #: G0372200

APPENDIX B
(LABORATORY TESTING)

LABORATORY TESTING

Laboratory tests were conducted on representative soil samples to verify or modify field soil classifications, and to evaluate the general physical properties and engineering characteristics of the soils encountered.

The following provides information about the testing procedures performed on representative soil samples:

- Moisture Content Tests (ASTM D2216) were performed on representative samples encountered in each test pit at each soil horizon.
- Sieve Analysis - No. 200 wash (ASTM C117) was performed on representative samples encountered in test pits I-1 and TP-2 - TP-5.
- Atterberg Limits (ASTM D4318) was performed on a representative soil sample encountered in test pits TP-4.
- Expansion Index (ASTM D4829) was performed on a representative soil sample encountered at I-1
- Moisture Content & Dry Density (ASTM D2216/D2937) was performed at TP-4.

The results of laboratory tests performed on specific samples are provided at the appropriate sample depth on the individual test pit logs. However, it is important to note that some variation of subsurface conditions may exist. Our geotechnical recommendations are based on our interpretation of these test results.

LIQUID AND PLASTIC LIMITS TEST REPORT

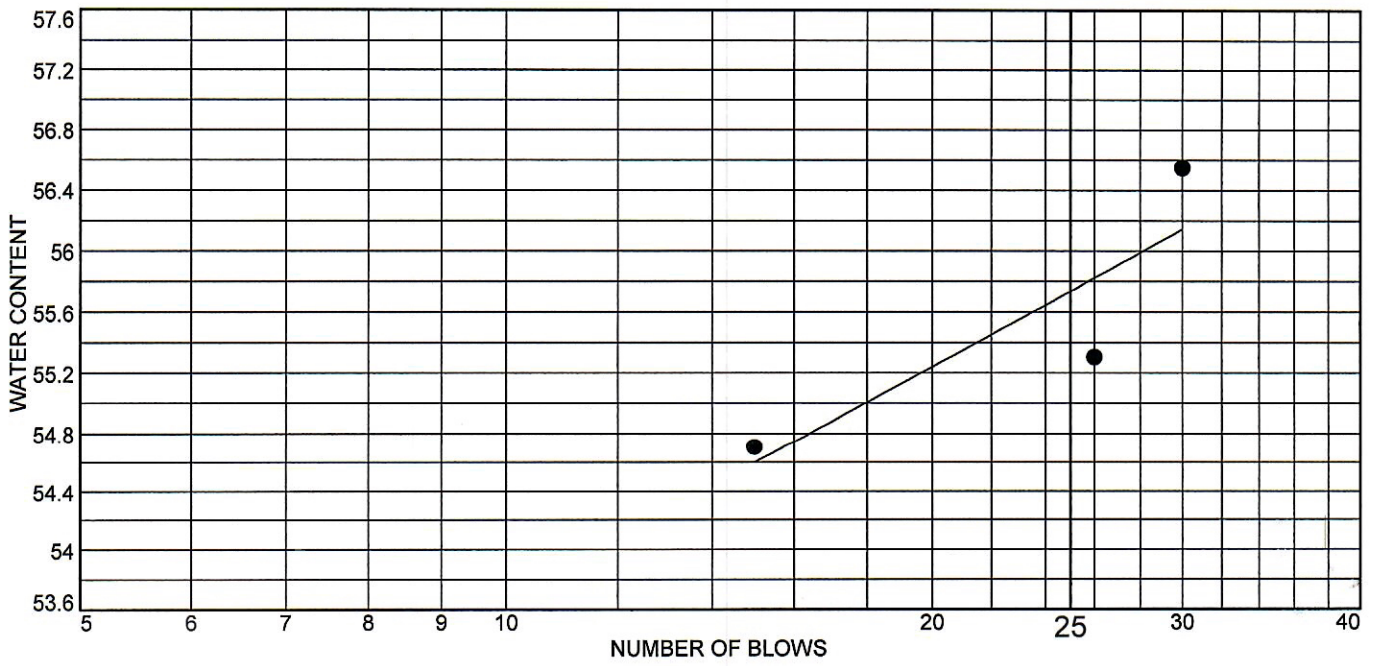
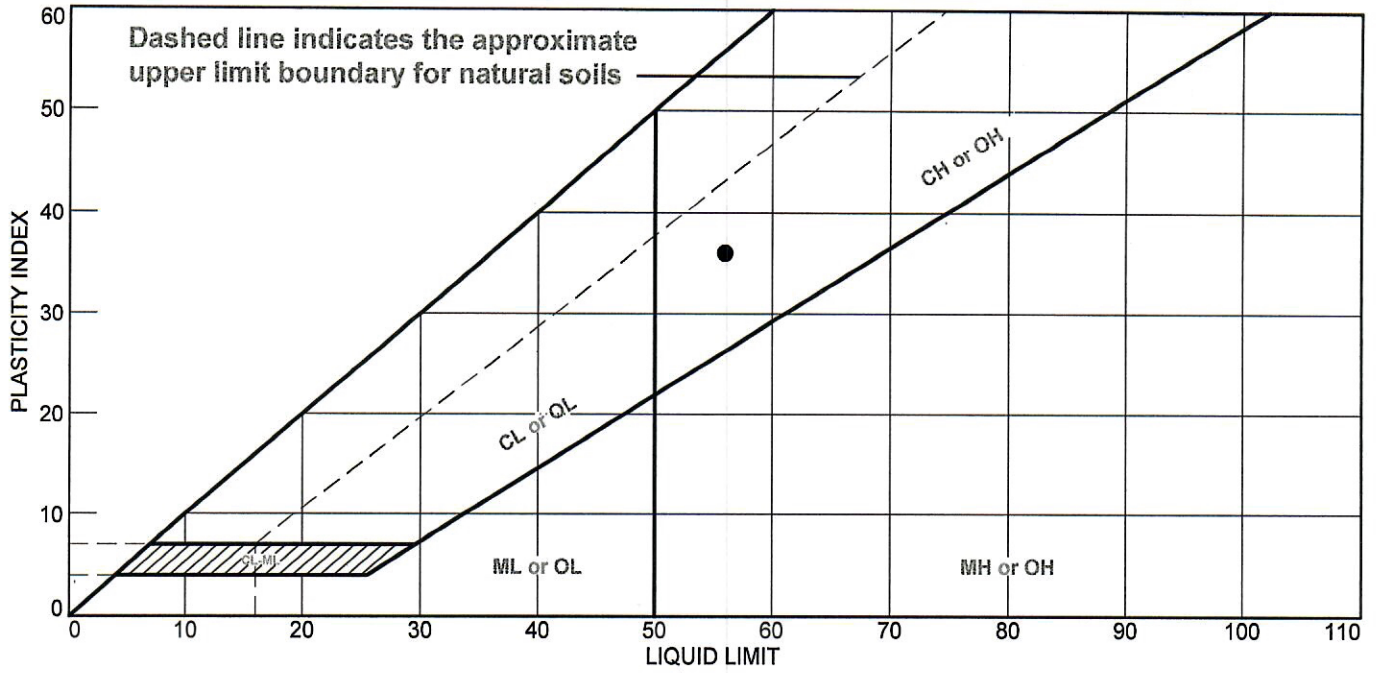

MATERIAL DESCRIPTION	LL	PL	PI	%<#40	%<#200	USCS
fat Clay	56	20	36	100	88.12	SC

Project No. G0372200 **Client:** Gravitate Capital, LLC
Project: Lockwod Creek Subdivision
Source of Sample: Native **Depth:** TP-1 @ 3.5
Sample Number: 370

Remarks:



Figure LPL-1

Tested By: JPT _____



Soil and Water Technologies, Inc.

Geotechnical, Construction Monitoring, Materials Testing & Erosion Consulting Services

Gravitate Capital, LLC
13563 NW Fuller Ln
Portland, OR 97229

April 20th, 2022
G0372200

Project: Lockwood Creek Subdivision
Report: Expansion Index of Soil
Figure 1; EI-1

Sample Identification

Testing was performed in accordance with the standards indicated. Our laboratory test results are summarized in the following table.

Laboratory Testing

Expansion Index of Soils (ASTM D4829)	
Test	TP-2 @ 2.0 in. Test Results
Initial Moisture Content, (%)	12.0
Initial Dry Unit Weight, (pcf)	102.3
Initial Height of Specimen, (inches)	1.00
Initial Dial Gauge Reading (inches)	0.0158
Final Dial Gauge Reading (inches)	0.0160
Initial Degree of Saturation, (%)	50.1
Final Moisture Content, (%)	31.7
Expansion Index, <i>EI</i>	13, Very Low