

Notes

1. This Preliminary Grading Plan indicates existing contours at 10' intervals due to the existing grades of approximately 10%, proposed contours at 10' intervals, and proposed pad grades.
2. Preliminary plans for drainage and erosion control are shown on a separate plan, consistent with applicable provisions of LCMC Chapter 18.320.
3. At preliminary stage, it appears that no retaining walls will be necessary. Preliminary earth quantities:
Excavation: 67,500 cy Embankment: 61,200 cy
4. All Erosion Control methods shall be indicated on the final Civil Engineering Plans per City of La Center Erosion Control Guidelines.

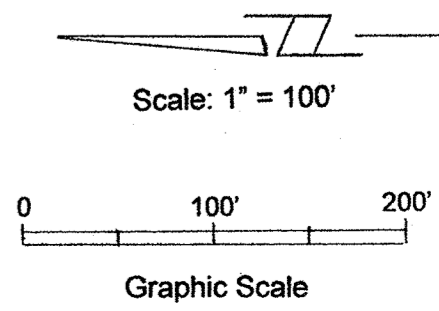

ED GREER Land Use Planning & Designs
 8002 NE Hwy 99 #546 Vancouver WA 98665
 360.904.4964 ed@greer.net

Applicant: **RK Land Development, LLC**
 1520 SW Eaton Blvd Battle Ground WA 98604
 360.608.3991 rkurtergina06@gmail.com

Sunrise Terrace
 a Residential Subdivision
 City of La Center WA

Preliminary Grading Plan