

TYPE 2 CURB RAMP-MIDBLOCK

PLAN #



CITY OF LA CENTER APPROVED

Anthony Peolopes

4/3/17

CITY ENGINEER

DATE

REVISIONS:	DATE:	DRAWN:	DESIGNED:
1	9/23/10	BES	BES
2	4/3/17	ALC	ALC

ST-8

TRUNCATED DOMES DETECTABLE WARNING PATTERN DETAIL

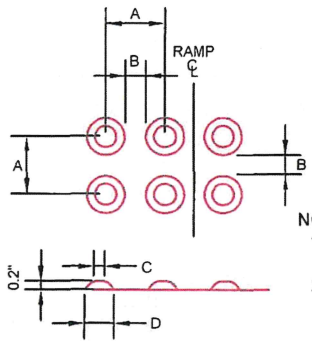

	MIN.	MAX.
A	1.6 "	2.4 "
B	0.65 "	1.5 "
C	50% TO 65% OF D	
D	0.9"	1.4"

NOTES:

1. THE DETECTABLE WARNING PATTERNS CAN BE CREATED BY ACCEPTABLE MEANS THAT WILL ACHIEVE THE TRUNCATED DOME DIMENSIONS AND SPACING SHOWN.
2. PLACE TRUNCATED DOME DETECTABLE WARNING TEXTURE IN THE LOWER 24" OF THE THROAT OF THE RAMP ONLY. COLOR OF TEXTURE COATING SHALL BE SAFETY YELLOW IN COMPLIANCE WITH WSDOT STANDARD SPECIFICATIONS.

TRUNCATED DOME DETAIL

PLAN #



CITY OF LA CENTER APPROVED

Anthony Perlopes

4-3-17

CITY ENGINEER

DATE

REVISIONS:	DATE:	DRAWN:	DESIGNED:

ST-7A